

SSCM Series – Bare Tube Bundle Shell & Tube Water to Oil Cooling

The SSC Series features all stainless steel construction. The proven fixed tubesheet design shell and tube heat exchanger offers the cost effectiveness that comes with having a highly standard design, while easily providing for various options to meet specific application requirements. Custom models are also available.

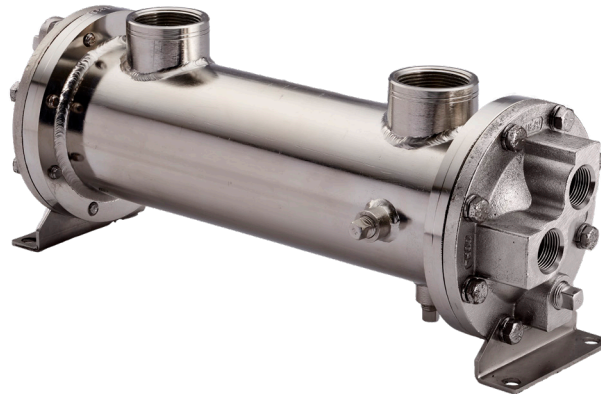

OPTIONS

For ASME/TEMAC/CRN ratings consult factory

How to Order

Model Series

SSCM - BSPP Shell side connections x BSPP Tube side connections

Model Size Selected

614, 624, 814, 824, 836, 1014, 1024, 1036, 1224, 1236, 1248, 1260, 1724, 1736, 1748, 1760, 1772
(See Performance Curve Chart on page 3 for sizes)

Baffle Spacing

1.3, 1.7, 2, 2.5, 3, 3.5, 4, 5, 6, 8.4
(See Performance Curve Chart on page 3 for options)

Tube Diameter Code

4 - 1/4"
(standard for 600 & 800 Series)
6 - 3/8"
(standard for 1000, 1200 & 1700 Series)

Tubeside

O - One Pass
T - Two Pass
F - Four Pass

Features

Interchangeable with TTP C and HC Series

All 316 Stainless Steel construction

Multiple Connections

- NPT x NPT
- SAE x NPT
- BSPP x BSP

End Bonnets removable for servicing
Mounting feet included (May be rotated in 90° increments)

Special ASME/TEMAC/CRN consult factory

Ratings

Maximum Operating Pressure - Shell Side 300 PSI*

Maximum Operating Pressure - Tube Side 150 PSI

Maximum Operating Temperature 300°F

Heat Removal Up to 350 HP (260 KW)
Oil Flow Rates Up to 160 U.S. GPM (350 L/MIN)

Materials

Tubes 316 Stainless steel

Tubesheets 316L Stainless steel

Shell 316L Stainless steel

Shell Connections 316L Stainless steel

Baffles 316 Stainless steel

End Bonnets 316 Stainless steel

Mounting Brackets Mild steel

Gaskets Nitrile rubber/cellulose fiber

Nameplate Aluminum foil

Selection Procedure

Performance Curves are based on 100SSU oil leaving the cooler 40°F higher than the incoming water temperature (40°F approach temperature). Curves are based on a 2:1 oil to water ratio.

STEP 1 Determine the Heat Load. This will vary with different systems, but typically coolers are sized to remove 25 to 50% of the input nameplate horsepower. (Example: 100 HP Power Unit x .33 = 33 HP Heat load.)
If BTU/HR is known: $HP = \frac{BTU/HR}{2545}$

STEP 2 Determine Approach Temperature.
Desired oil leaving cooler °F – Water Inlet temp. °F = Actual Approach

STEP 3 Determine Curve Horsepower Heat Load. Enter the information from above:
 $HP \text{ heat load} \times \frac{40}{\text{Actual Approach}} \times \frac{\text{Viscosity}}{\text{Correction A}} = \text{Curve Horsepower}$

STEP 4 Enter curves at oil flow through cooler and curve horsepower. Any curve above the intersecting point will work.

STEP 5 Determine Oil Pressure Drop from Curves. Multiply pressure drop from curve by correction factor B found on oil viscosity correction curve.
● = 5 PSI ■ = 10 PSI ▲ = 20 PSI

Oil Temperature

Oil coolers can be selected by using entering or leaving oil temperatures.

Typical operating temperature ranges are:

Hydraulic Motor Oil	110°F - 130°F
Hydrostatic Drive Oil	130°F - 180°F
Lube Oil Circuits	110°F - 130°F
Automatic Transmission Fluid	200°F - 300°F

Desired Reservoir Temperature

Return Line Cooling: Desired temperature is the oil temperature leaving the cooler. This will be the same temperature that will be found in the reservoir.

Off-Line Recirculation Cooling Loop: Desired temperature is the temperature entering the cooler. In this case, the oil temperature change must be determined so that the actual oil leaving temperature can be found. Calculate the oil temperature change (Oil #T) with this formula:

$$\text{Oil \#T} = (\text{BTUs/HR}) / (\text{GPM Oil Flow} \times 210)$$

To calculate the oil leaving temperature from the cooler, use this formula:

$$\text{Oil Leaving Temperature} = \text{Oil Entering Temperature} - \text{Oil \#T}$$

This formula may also be used in any application where the only temperature available is the entering oil temperature.

Oil Pressure Drop: Most systems can tolerate a pressure drop through the heat exchanger of 20 to 30 PSI. Excessive pressure drop should be avoided. Care should be taken to limit pressure drop to 5 PSI or less for case drain applications where high back pressure may damage the pump shaft seals.

Viscosity Correction

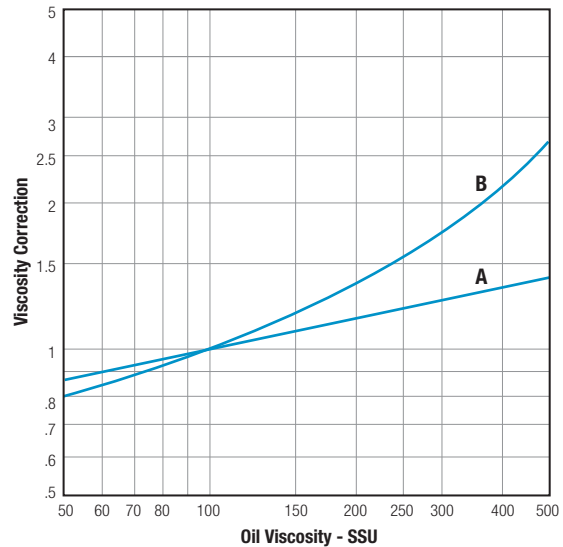

Maximum Flow Rates

Example Model No.
SSC - 1024 - 2 - 6 - F

Unit Size	Baffle Spacing	Shell Side (GPM)	Tube Side (GPM)		
			O	T	F
600	1.3, 3	19, 29	48	24	12
800	1.7, 4	32, 69	84	42	21
1000	2, 5	41, 69	146	73	37
1200	2.5, 6	60, 115	224	112	56
1700	3.5, 8.4	125, 253	465	232	116

Exceptions to Maximum Shell Side Flows

SSC-814-4-4-*	63 GPM Max.
SSC-1014-2-6-*	33 GPM Max.
SSC-1014-5-6-*	66 GPM Max.
SSC-1724-3.5-6-*	105 GPM Max.
SSC-1724-8.4-6-*	200 GPM Max.

Caution: Incorrect installation can cause this product to fail prematurely, causing the shell side and tube side fluids to intermix.

Piping Diagram

One Pass

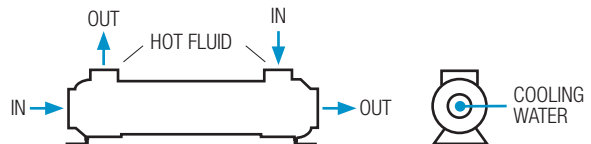

Two and Four Pass

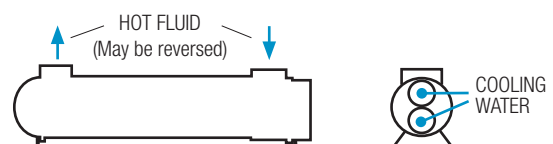

Specific applications may have different piping arrangements. Contact factory for assistance.

Dimensions

One Pass

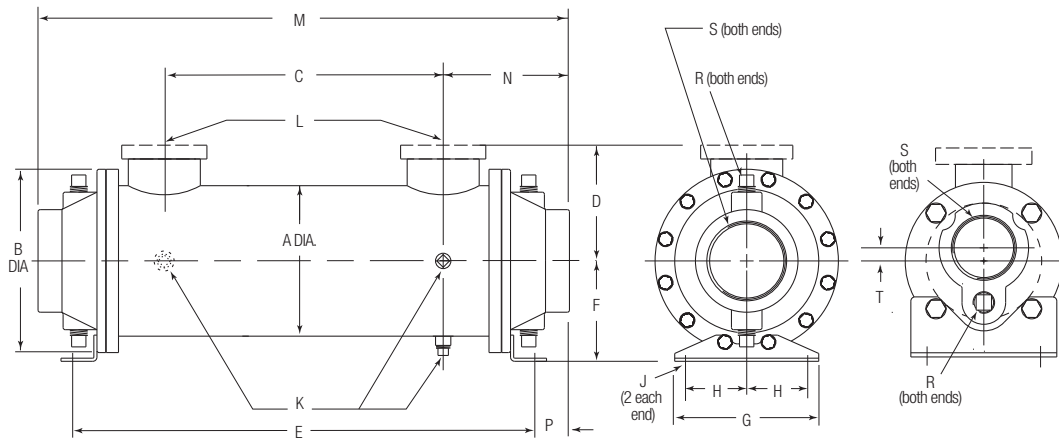

All models except
SSC-600

SSC-600

Model	A	B	C	D		E	F	G	H	J	K NPT	L		M	N	P	R NPT	S NPT/ BSPP	T
				NPT/ BSPP SAE O-Ring	SAE Flange							NPT/ BSPP Flange	SAE O-Ring						
614	3.25	4.50	10.00	2.62	2.88	16.38	2.75	4.18	1.62	0.44 Dia.	0.25 (3)	1.00	#16 1½-12 UNF-2B	17.18	3.59	0.40	0.38 (2)	1.50	0.38
624	3.25	4.50	20.00	2.62	2.88	26.38	2.75	4.18	1.62	0.44 Dia.	0.25 (3)	1.00		27.18	3.59	0.40	0.38 (2)	1.50	0.38
814	4.25	6.00	9.00	3.25	3.50	16.62	3.50	4.25	1.75	0.44 Dia.	0.25 (3)	1.50	#24 1½-12 UNF-2B	17.88	4.44	0.63	0.38 (2)	2.00	—
824	4.25	6.00	19.00	3.25	3.50	26.62	3.50	4.25	1.75	0.44 Dia.	0.25 (3)	1.50		27.88	4.44	0.63	0.38 (2)	2.00	—
836	4.25	6.00	31.00	3.25	3.50	38.62	3.50	4.25	1.75	0.44 Dia.	0.25 (3)	1.50	#24 1½-12 UNF-2B	39.88	4.44	0.63	0.38 (2)	2.00	—
1014	5.25	6.75	9.00	3.75	4.00	17.12	4.00	5.25	2.00	.50 x .75	0.25 (3)	1.50		19.09	5.05	0.92	.38 (4)	2.00	—
1024	5.25	6.75	19.00	3.75	4.00	27.12	4.00	5.25	2.00	.50 x .75	0.25 (3)	1.50	#24 1½-12 UNF-2B	29.09	5.05	0.92	.38 (4)	2.00	—
1036	5.25	6.75	31.00	3.75	4.00	39.12	4.00	5.25	2.00	.50 x .75	0.25 (3)	1.50		41.09	5.05	0.92	.38 (4)	2.00	—
1224	6.25	7.75	18.25	4.25	4.88	27.13	4.50	6.25	2.50	.50 x .75	0.38 (3)	2.00	#32 2½-12 UNF-2B	30.00	5.87	1.43	.50 (4)	3.00	—
1236	6.25	7.75	30.25	4.25	4.88	39.13	4.50	6.25	2.50	.50 x .75	0.38 (3)	2.00		42.00	5.87	1.43	.50 (4)	3.00	—
1248	6.25	7.75	42.25	4.25	4.88	51.13	4.50	6.25	2.50	.50 x .75	0.38 (3)	2.00	#32 2½-12 UNF-2B	54.00	5.87	1.43	.50 (4)	3.00	—
1260	6.25	7.75	55.25	4.25	4.88	63.13	4.50	6.25	2.50	.50 x .75	0.38 (3)	2.00		66.00	5.87	1.43	.50 (4)	3.00	—
1724	8.62	10.50	17.00	5.84	6.81	27.50	5.75	8.25	3.50	.62 x .88	0.38 (3)	3.00	—	31.47	7.23	1.99	.50 (4)	4.00	—
1736	8.62	10.50	29.00	5.84	6.81	39.50	5.75	8.25	3.50	.62 x .88	0.38 (3)	3.00	—	43.47	7.23	1.99	.50 (4)	4.00	—
1748	8.62	10.50	41.00	5.84	6.81	51.50	5.75	8.25	3.50	.62 x .88	0.38 (3)	3.00	—	55.47	7.23	1.99	.50 (4)	4.00	—
1760	8.62	10.50	53.00	5.84	6.81	63.50	5.75	8.25	3.50	.62 x .88	0.38 (3)	3.00	—	67.47	7.23	1.99	.50 (4)	4.00	—
1772	8.62	10.50	65.00	5.84	6.81	75.50	5.75	8.25	3.50	.62 x .88	0.38 (3)	3.00	—	79.47	7.23	1.99	.50 (4)	4.00	—

NOTE: We reserve the right to make reasonable design changes without notice. Consult factory. All dimensions are inches.

Dimensions

Two Pass

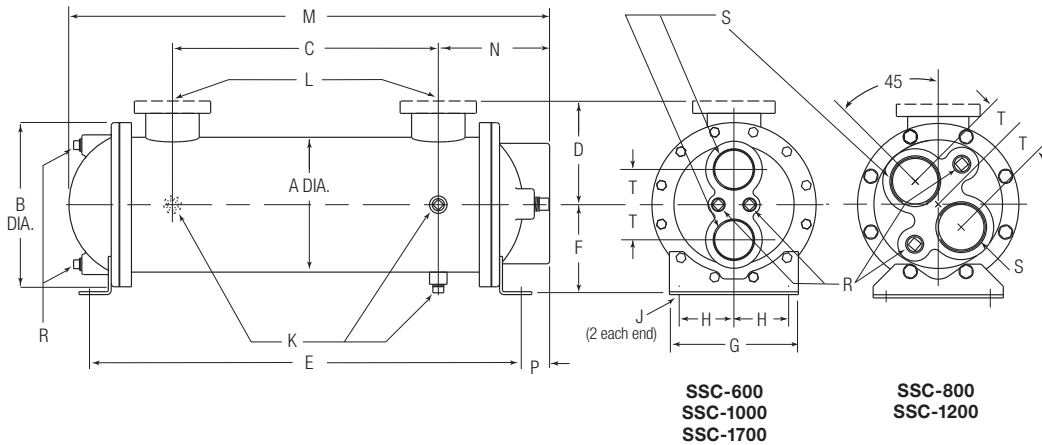

Model	A	B	C	D		E	F	G	H	J	K NPT	L		M	N	P	R NPT	S NPT/ BSPP	T
				NPT/ BSPP SAE O-Ring	SAE Flange							NPT/ BSPP Flange	SAE O-Ring						
614	3.25	4.50	10.00	2.62	2.88	16.38	2.75	4.18	1.62	0.44 Dia.	0.25 (3)	1.00	#16 1½-12 UNF-2B	17.12	3.56	0.38	0.38 (2)	1.50	1.00
624	3.25	4.50	20.00	2.62	2.88	26.38	2.75	4.18	1.62	0.44 Dia.	0.25 (3)	1.00	#16 1½-12 UNF-2B	27.12	3.56	0.38	0.38 (2)	1.50	1.00
814	4.25	6.00	9.00	3.25	3.50	16.62	3.50	4.25	1.75	0.44 Dia.	0.25 (3)	1.50	#24 1⅞-12 UNF-2B	17.88	4.44	0.63	0.38 (2)	1.25	1.06
824	4.25	6.00	19.00	3.25	3.50	26.62	3.50	4.25	1.75	0.44 Dia.	0.25 (3)	1.50		27.88	4.44	0.63	0.38 (2)	1.25	1.06
836	4.25	6.00	31.00	3.25	3.50	38.62	3.50	4.25	1.75	0.44 Dia.	0.25 (3)	1.50		39.88	4.44	0.63	0.38 (2)	1.25	1.06
1014	5.25	6.75	9.00	3.75	4.00	17.12	4.00	5.25	2.00	.50 x .75	0.25 (3)	1.50		18.62	5.00	0.94	.38 (4)	1.50	1.50
1024	5.25	6.75	19.00	3.75	4.00	27.12	4.00	5.25	2.00	.50 x .75	0.25 (3)	1.50		28.62	5.00	0.94	.38 (4)	1.50	1.50
1036	5.25	6.75	31.00	3.75	4.00	39.12	4.00	5.25	2.00	.50 x .75	0.25 (3)	1.50		40.62	5.00	0.94	.38 (4)	1.50	1.50
1224	6.25	7.75	18.25	4.25	4.88	27.13	4.50	6.25	2.50	.50 x .75	0.38 (3)	2.00	#32 2½-12 UNF-2B	29.02	5.43	1.00	.50 (4)	2.00	1.56
1236	6.25	7.75	30.25	4.25	4.88	39.13	4.50	6.25	2.50	.50 x .75	0.38 (3)	2.00		41.03	5.43	1.00	.50 (4)	2.00	1.56
1248	6.25	7.75	42.25	4.25	4.88	51.13	4.50	6.25	2.50	.50 x .75	0.38 (3)	2.00		53.03	5.43	1.00	.50 (4)	2.00	1.56
1260	6.25	7.75	55.25	4.25	4.88	63.13	4.50	6.25	2.50	.50 x .75	0.38 (3)	2.00		65.03	5.43	1.00	.50 (4)	2.00	1.56
1724	8.62	10.50	17.00	5.84	6.81	27.50	5.75	8.25	3.50	.62 x .88	0.38 (3)	3.00	—	30.62	7.06	1.81	.50 (4)	2.50	2.25
1736	8.62	10.50	29.00	5.84	6.81	39.50	5.75	8.25	3.50	.62 x .88	0.38 (3)	3.00	—	42.62	7.06	1.81	.50 (4)	2.50	2.25
1748	8.62	10.50	41.00	5.84	6.81	51.50	5.75	8.25	3.50	.62 x .88	0.38 (3)	3.00	—	54.62	7.06	1.81	.50 (4)	2.50	2.25
1760	8.62	10.50	53.00	5.84	6.81	63.50	5.75	8.25	3.50	.62 x .88	0.38 (3)	3.00	—	66.62	7.06	1.81	.50 (4)	2.50	2.25
1772	8.62	10.50	65.00	5.84	6.81	75.50	5.75	8.25	3.50	.62 x .88	0.38 (3)	3.00	—	78.62	7.06	1.81	.50 (4)	2.50	2.25

NOTE: We reserve the right to make reasonable design changes without notice. Consult factory. All dimensions are inches.

Dimensions

Four Pass

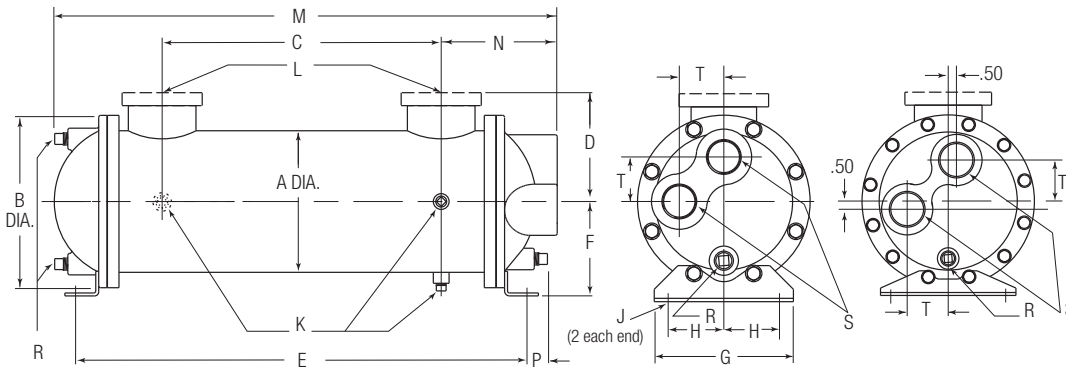

All models except
SSC-1700

SSC-1700

Model	A	B	C	D		E	F	G	H	J	K NPT	L		M	N	P	R NPT	S NPT/ BSPP	T
				NPT/ BSPP SAE O-Ring	SAE Flange							NPT/ BSPP Flange	SAE O-Ring						
614	3.25	4.50	10.00	2.62	2.88	16.38	2.75	4.18	1.62	0.44 Dia.	.25 (3)	1.00	#16 1 ¹ / ₁₆ -12 UNF-2B	17.12	3.56	0.38	.38 (2)	.75	1.00
624	3.25	4.50	20.00	2.62	2.88	26.38	2.75	4.18	1.62	0.44 Dia.	.25 (3)	1.00	#16 1 ¹ / ₁₆ -12 UNF-2B	27.12	3.56	0.38	.38 (2)	.75	1.00
814	4.25	6.00	9.00	3.25	3.50	16.62	3.50	4.25	1.75	0.44 Dia.	.25 (3)	1.50	#24 1 ¹ / ₁₆ -12 UNF-2B	17.88	4.44	0.63	.38 (3)	.75	1.06
824	4.25	6.00	19.00	3.25	3.50	26.62	3.50	4.25	1.75	0.44 Dia.	.25 (3)	1.50		27.88	4.44	0.63	.38 (3)	.75	1.06
836	4.25	6.00	31.00	3.25	3.50	38.62	3.50	4.25	1.75	0.44 Dia.	.25 (3)	1.50		39.88	4.44	0.63	.38 (3)	.75	1.06
1014	5.25	6.75	9.00	3.75	4.00	17.12	4.00	5.25	2.00	.50 x .75	.25 (3)	1.50		18.81	4.81	0.75	.38 (3)	1.00	1.50
1024	5.25	6.75	19.00	3.75	4.00	27.12	4.00	5.25	2.00	.50 x .75	.25 (3)	1.50	28.81	4.81	0.75	.38 (3)	1.00	1.50	
1036	5.25	6.75	31.00	3.75	4.00	39.12	4.00	5.25	2.00	.50 x .75	.25 (3)	1.50	40.81	4.81	0.75	.38 (3)	1.00	1.50	
1224	6.25	7.75	18.25	4.25	4.88	27.13	4.50	6.25	2.50	.50 x .75	.38 (3)	2.00	#32 2 ¹ / ₂ -12 UNF-2B	29.13	5.44	1.00	.38 (3)	1.50	1.56
1236	6.25	7.75	30.25	4.25	4.88	39.13	4.50	6.25	2.50	.50 x .75	.38 (3)	2.00		41.13	5.44	1.00	.38 (3)	1.50	1.56
1248	6.25	7.75	42.25	4.25	4.88	51.13	4.50	6.25	2.50	.50 x .75	.38 (3)	2.00		53.13	5.44	1.00	.38 (3)	1.50	1.56
1260	6.25	7.75	55.25	4.25	4.88	63.13	4.50	6.25	2.50	.50 x .75	.38 (3)	2.00		65.13	5.44	1.00	.38 (3)	1.50	1.56
1724	8.62	10.50	17.00	5.84	6.81	27.50	5.75	8.25	3.50	.62 x .88	.38 (3)	3.00	—	29.86	7.06	1.81	.38 (3)	2.00	2.50
1736	8.62	10.50	29.00	5.84	6.81	39.50	5.75	8.25	3.50	.62 x .88	.38 (3)	3.00	—	41.86	7.06	1.81	.38 (3)	2.00	2.50
1748	8.62	10.50	41.00	5.84	6.81	51.50	5.75	8.25	3.50	.62 x .88	.38 (3)	3.00	—	53.86	7.06	1.81	.38 (3)	2.00	2.50
1760	8.62	10.50	53.00	5.84	6.81	63.50	5.75	8.25	3.50	.62 x .88	.38 (3)	3.00	—	65.86	7.06	1.81	.38 (3)	2.00	2.50
1772	8.62	10.50	65.00	5.84	6.81	75.50	5.75	8.25	3.50	.62 x .88	.38 (3)	3.00	—	77.86	7.06	1.81	.38 (3)	2.00	2.50

NOTE: We reserve the right to make reasonable design changes without notice. Consult factory. All dimensions are inches.