

# RM Series – Industrial Air Cooled Copper Tube/Aluminum Fins

The compact Industrial RM Series is an efficient, low cost, low flow design that mounts behind an existing TEFC motor. It provides optimal performance for case drain cooling applications. This compact design includes multiple pass options as standard.

- Mounts behind existing TEFC motor for compact, low cost application
- Utilizes electric motor fan air flow
- Ideal for case drain and low flow applications
- Protected core
- Compact, efficient design
- Low flow & heat removal
- SAE, NPT or metric conversion
- Mounting brackets included



## How to Order

### Model Series

**RM**

### Model Size Selected

**08, 19, 24**

(See Performance Curve Chart on page 2 for sizes)

### Number of Passes\*

**1** - One Pass  
**2** - Two Pass  
**4\*** - Four Pass

\* Four pass only available on RM-08 size

### Connection Type

**1** - NPT  
**2** - SAE  
**3** - BSPP

### Bypass Setting\*

**Blank** - No Bypass  
**30** - 30 PSI  
**60** - 60 PSI

\*Bypass available on RM-08 in one and two pass configuration, and RM-19/24 in one pass only. This is a partial flow pressure bypass only. It is not designed to be a full flow system bypass.

## Ratings

**Maximum Operating Pressure**  
300 PSI

**Test Pressure**  
300 PSI

**Maximum Operating Temperature**  
350°F

## Materials

**Tubes** Copper

**Fins** Aluminum

**Turbulators** Aluminum

**Cabinet** Steel with powder coat finish

**Filter** Stainless frame with washable media

**Manifolds** Copper (RM-08)  
Steel (RM-19 & RM-24)

**Connections** Brass (RM-08)  
Steel (RM-19 & RM-24)

**Nameplate** Aluminum foil

# Performance Curves

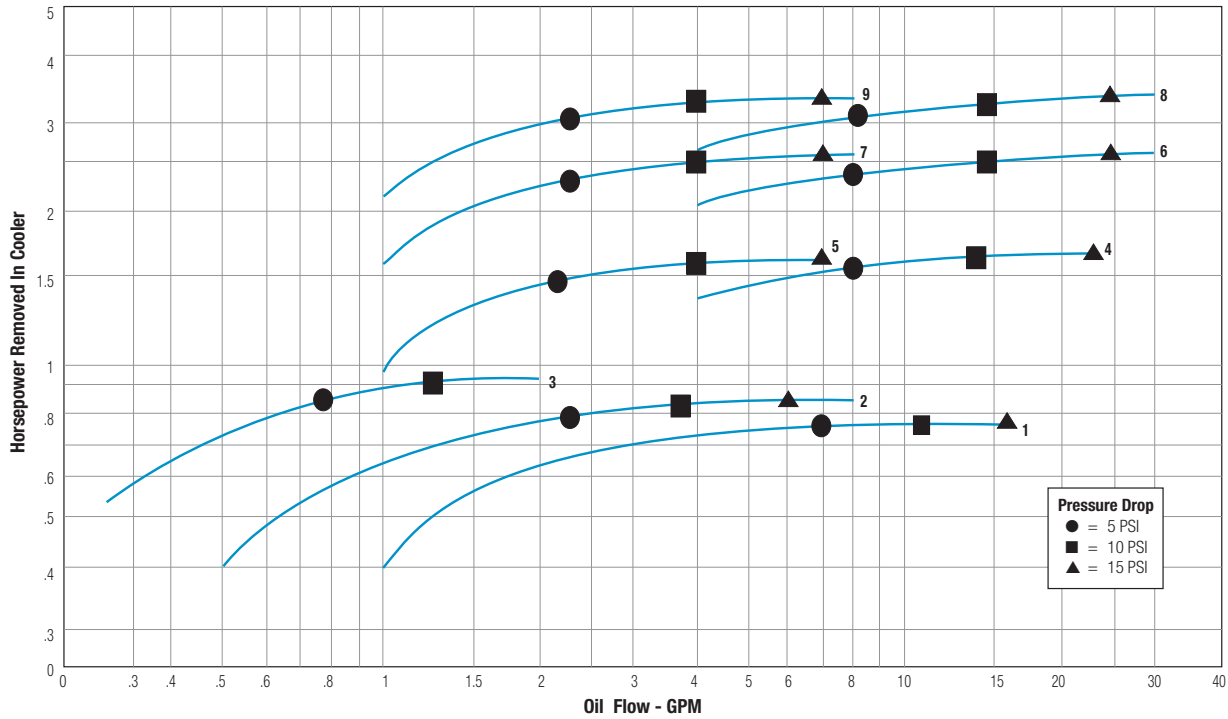

## Selection Procedure

Curve	Model	TEFC Motor Frame Size
1	RM-08-1	48-184
2	RM-08-2	48-184
3	RM-08-4	48-184
4	RM-19-1	213-256
5	RM-19-2	213-256
6	RM-24-1	254-286
7	RM-24-2	254-286
8	RM-24-1	324-365
9	RM-24-2	324-365

## Oil Pressure Correction

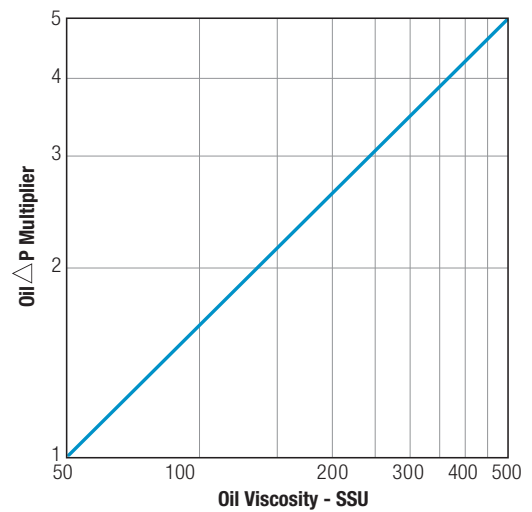

## C<sub>v</sub> Viscosity Correction

Average Oil Temp °F	OIL				
	SAE 5 110 SSU at 100°F 40 SSU at 210°F	SAE 10 150 SSU at 100°F 43 SSU at 210°F	SAE 20 275 SSU at 100°F 50 SSU at 210°F	SAE 30 500 SSU at 100°F 65 SSU at 210°F	SAE 40 750 SSU at 100°F 75 SSU at 210°F
100	1.14	1.22	1.35	1.58	1.77
150	1.01	1.05	1.11	1.21	1.31
200	.99	1.00	1.01	1.08	1.10
250	.95	.98	.99	1.00	1.00

# Selection Procedure

Performance Curves are based on 50SSU oil leaving the cooler 40°F higher than the ambient air temperature used for cooling and 1800 RPM motor speed. This is also referred to as a 40° approach temperature.

**STEP 1 Determine the Heat Load.** This will vary with different systems, but typically coolers are sized to remove 25 to 50% of the input nameplate horsepower.

(Example: 100 HP Power Unit x .33 = 33 HP Heat load. For 1200 RPM motors, multiply Heat Load by 1.5.)

If BTU/HR is known:  $HP = \frac{BTU/HR}{2545}$

**STEP 2 Determine Approach Temperature.**

Desired oil leaving cooler °F – Ambient air temp.

°F = Actual Approach

**STEP 3 Determine Curve Horsepower Heat Load.** Enter the information from above:

Horsepower heat load x  $\frac{40 \times Cv}{\text{Actual Approach}}$  = Curve Horsepower

**STEP 4 Enter curves** at oil flow through cooler and curve horsepower.

Any curve above the intersecting point will work.

**STEP 5 Determine Oil Pressure Drop from Curves:**

l = 5 PSI n = 10 PSI s = 20 PSI Multiply pressure drop from curve by correction factor found in oil  $\Delta P$  correction curve.

## Desired Reservoir Temperature

**Return Line Cooling:** Desired temperature is the oil temperature leaving the cooler. This will be the same temperature that will be found in the reservoir.

**Off-Line Recirculation Cooling Loop:** Desired temperature is the oil temperature entering the cooler. In this case, the oil temperature change must be determined so that the actual oil leaving temperature can be found.

Calculate the oil temperature change (oil  $\Delta T$ ) with this formula:

Oil  $\Delta T = (BTU's/HR) / (GPM \text{ Oil Flow} \times 210)$ .

To calculate the oil leaving temperature from the cooler, use this formula:

Oil Leaving Temp. = Oil Entering Temp – Oil  $\Delta T$ .

This formula may also be used in any application where the only temperature available is the entering oil temperature.

**Oil Pressure Drop:** Most systems can tolerate a pressure drop through the heat exchanger of 20 to 30 PSI. Excessive pressure drop should be avoided. Care should be taken to limit pressure drop to 5 PSI or less for case drain applications where high back pressure may damage the pump shaft seals.

## Oil Temperature

Typical operating temperature ranges are:

Hydraulic Motor Oil	110°- 130°F
Hydrostatic Drive Oil	130°- 180°F
Bearing Lube Oil	120°- 160°F
Lube Oil Circuits	110°- 130°F

# Dimensions

## RM-08-1 One Pass

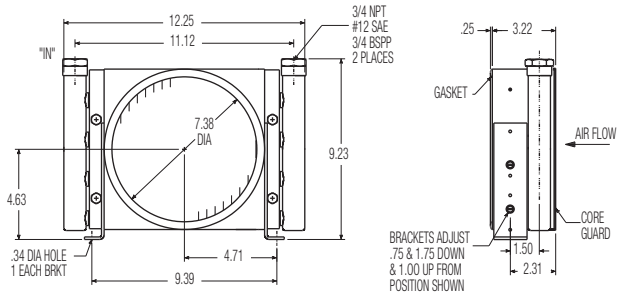

## RM-08-2 Two Pass

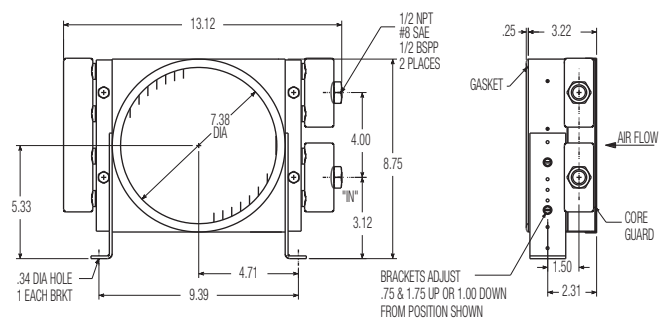

## RM-08-4 Four Pass

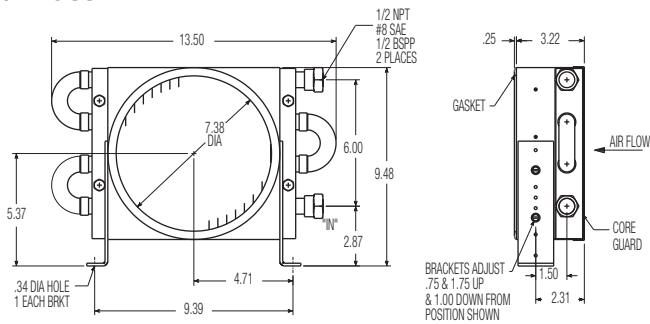

## RM-19-1, RM-24-1 One Pass

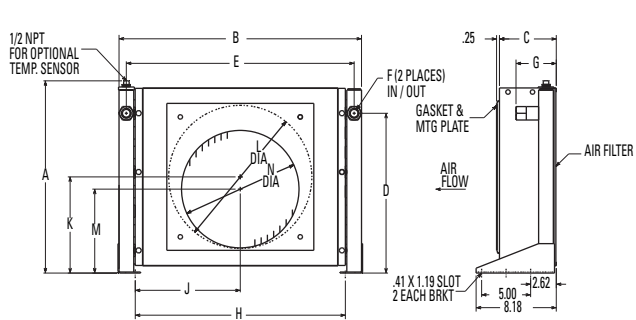

## RM-19-2, RM-24-2 Two Pass

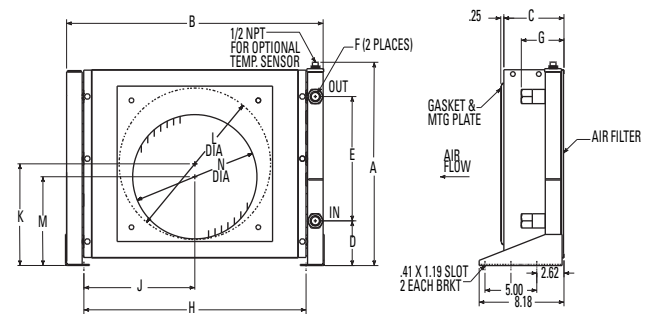

Model	A	B	C	D	E	F		G		H	J	K	L	M	N	Weight LBS
						SAE	NPT & BSPP	SAE	NPT & BSPP							
RM-19-1	13.62	16.00	5.11	10.31	15.00	#12	.75	3.05	4.12	13.96	7.38	6.81	10.38	5.81	7.50	16
RM-19-2	13.62	16.50	5.11	4.31	6.00	#12	.75	3.05	4.12	13.96	7.38	6.81	10.31	5.81	7.50	16
RM-24-1	19.62	24.75	5.85	16.31	23.25	#12	.75	3.05	4.12	21.44	10.72	9.81	14.62	8.56	12.00	31
RM-24-2	19.62	24.75	5.85	4.31	12.00	#12	.75	3.05	4.12	21.44	10.72	9.81	14.62	8.56	12.00	31

NOTE: All dimensions in inches. We reserve the right to make reasonable design changes without notice.