

HCR Series – Removable Bare Tube Bundle Shell & Tube

The HCR Series is a unique design allowing the tube bundle to be removed for cleaning or exchange while the shell remains mounted and shell connections remain undisturbed. By only replacing the tube bundle portion of the cooler it will cut down on labor and saving on cost of replacing a complete cooler allowing for quicker pay-back.

The HCR is based off of the HC 1200 and 1700. All performance for heat rejection and pressure drop are the same.



How to Order

Model Series

HCR - NPT Shell Side Connections x NPT Tube Side Connections
HCRS - SAE ORB Shell Side Connections x NPT Tube Side Connections
HCRF - SAE Code 61 Flanges on Shell Side (UNC Threads) x NPT Tube Side Connections
HCRA+ ** - 150# ASME RF Flanges on Shell Side x NPT Tube Side Connections.
 (+Shell Maximum Pressure Rating is 150 psi)
 ** 2000 series sizes are only HCRA, not available with other port configurations.

Model Size Selected

1224, 1236, 1248, 1724, 1736, 1748
 (See Performance Curve Chart on page 3 for sizes or **XSelector®** sizing program)

Baffle Spacing

2.5, 3.5, 6, 8.4
 (Baffle spacing is dependent on applicable sizes found in sizing charts on page 3 or can be determined by using **XSelector®** sizing program)

Tube Diameter Code

6 - 3/8"

Tubeside Passes

O - One Pass
T - Two Pass

Replacement Bundle Assemblies

Model Code	Size	Baffle Spacing	Shell Length		
			24	36	48
HCR-12**-2.5-*	1200	2.5	52893	52895	52897
HCR-12**-6-*		6	52894	52896	52898
HCR-17**-3.5-*	1700	3.5	52901	52903	52905
HCR-17**-8.4-*		8.4	52902	52904	52906

Features

1200/1700 Interchangeable with TTP HC and C Series

Multiple Connection Options

- NPT x NPT
- SAE x NPT
- SAE Code 61 x NPT
- 150# ASME RF Flanges x NPT

End Bonnets Removable for Servicing

Mounting Feet Included (May be rotated)

Materials

Tubes Copper

Tubesheet Carbon Steel

Shell Carbon Steel

Baffles Carbon Steel

End Bonnets Cast Iron

Mounting Brackets Carbon Steel

Gaskets Nitrile Rubber/Cellulose Fiber

Nameplate Aluminum Foil

Ratings

Maximum Operating Pressure - Shell Side
 300 PSI

Maximum Operating Pressure - Tube Side
 150 PSI

Maximum Operating Temperature
 300°F

Selection Procedure

Performance Curves are based on 100SSU oil leaving the cooler 40°F higher than the incoming water temperature (40°F approach temperature). Curves are based on a 2:1 oil to water ratio.

STEP 1 Determine the Heat Load. This will vary with different systems, but typically coolers are sized to remove 25 to 50% of the input nameplate horsepower. (Example: 100 HP Power Unit x .33 = 33 HP Heat load.)
If BTU/HR is known: $HP = \frac{BTU/HR}{2545}$

STEP 2 Determine Approach Temperature.
Desired oil leaving cooler °F – Water Inlet temp. °F = Actual Approach

STEP 3 Determine Curve Horsepower Heat Load. Enter the information from above:
 $HP \text{ heat load} \times \frac{40}{\text{Actual Approach}} \times \frac{\text{Viscosity}}{\text{Correction A}} = \text{Curve Horsepower}$

STEP 4 Enter curves at oil flow through cooler and curve horsepower. Any curve above the intersecting point will work.

STEP 5 Determine Oil Pressure Drop from Curves. Multiply pressure drop from curve by correction factor B found on oil viscosity correction curve.
● = 5 PSI ■ = 10 PSI ▲ = 20 PSI

Oil Temperature

Oil coolers can be selected by using entering or leaving oil temperatures.

Typical operating temperature ranges are:

Hydraulic Motor Oil	110°F - 130°F
Hydrostatic Drive Oil	130°F - 180°F
Lube Oil Circuits	110°F - 130°F
Automatic Transmission Fluid	200°F - 300°F

Desired Reservoir Temperature

Return Line Cooling: Desired temperature is the oil temperature leaving the cooler. This will be the same temperature that will be found in the reservoir.

Off-Line Recirculation Cooling Loop: Desired temperature is the temperature entering the cooler. In this case, the oil temperature change must be determined so that the actual oil leaving temperature can be found. Calculate the oil temperature change (Oil #T) with this formula:

$$\text{Oil \#T} = (\text{BTUs/HR}) / (\text{GPM Oil Flow} \times 210)$$

To calculate the oil leaving temperature from the cooler, use this formula:

$$\text{Oil Leaving Temperature} = \text{Oil Entering Temperature} - \text{Oil \#T}$$

This formula may also be used in any application where the only temperature available is the entering oil temperature.

Oil Pressure Drop: Most systems can tolerate a pressure drop through the heat exchanger of 20 to 30 PSI. Excessive pressure drop should be avoided. Care should be taken to limit pressure drop to 5 PSI or less for case drain applications where high back pressure may damage the pump shaft seals.

Viscosity Correction

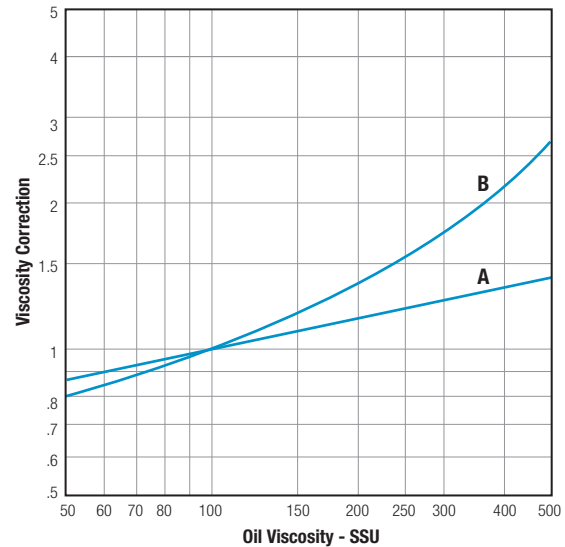

Maximum Flow Rates

Example Model No.

HC - 1024 - 2 - 6 - F

Unit Size	Baffle Spacing	Shell Side (GPM)	Tube Side (GPM)		
			O	T	F
1200	2.5, 6	60, 115	224	112	56
1700	3.5, 8.4	125, 253	465	232	116

Exceptions to Maximum Shell Side Flows

HC-1724-3.5-6-*	105 GPM Max.
HC-1724-8.4-6-*	200 GPM Max.

Caution: Incorrect installation can cause this product to fail prematurely, causing the shell and tube side fluids to intermix.

Piping Diagram

One Pass

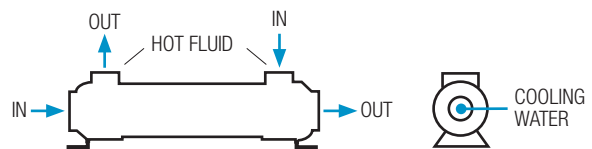

Two Pass

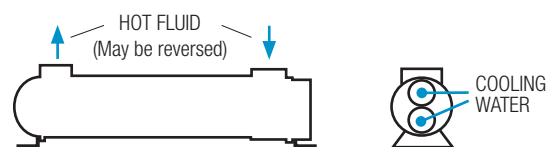

Specific applications may have different piping arrangements. Contact factory for assistance.

Performance Curves

HCR-1200/1700

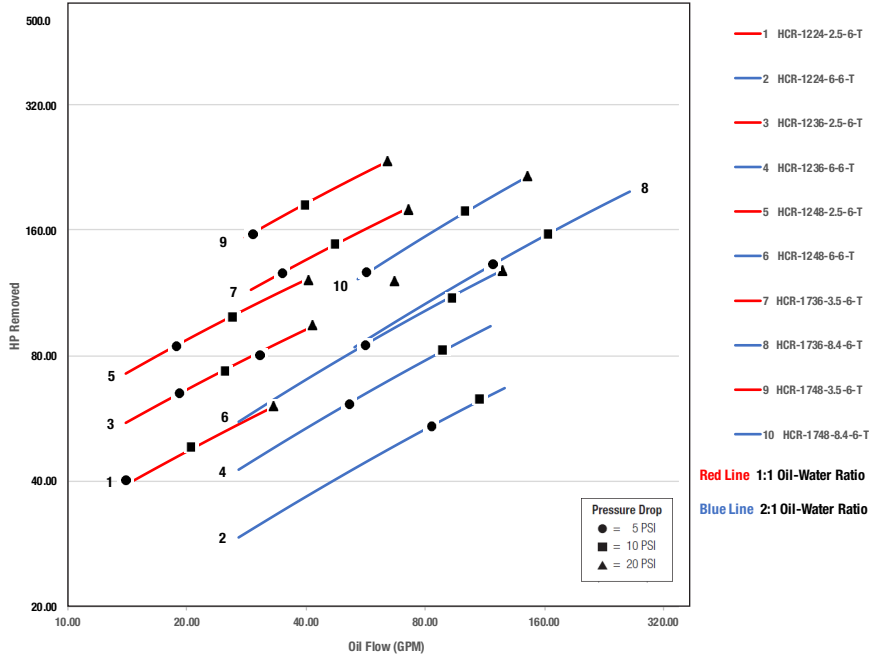

Curve Number	Model	Shipping Weight (LBS)
1	HCR-1224-2.5-6-T	85
2	HCR-1224-6-6-T	85
3	HCR-1236-2.5-6-T	110
4	HCR-1236-6-6-T	110
5	HCR-1248-2.5-6-T	135
6	HCR-1248-6-6-T	135
7	HCR-1736-3.5-6-T	180
8	HCR-1736-8.4-6-T	180
9	HCR-1748-3.5-6-T	220
10	HCR-1748-8.4-6-T	220

Shipping weights are approximate.

Dimensions

One Pass

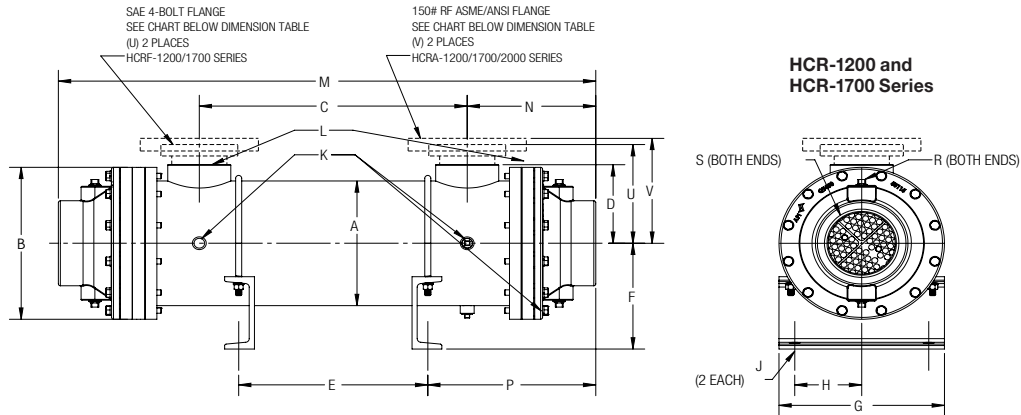

Model	A	B	C	D	E	F	G	H	J	K	L		M	N	P	R NPT	S NPT	U (HCRF)	V (HCRA)
											NPT/BSPP	SAE							
1224	6.26	7.75	18.25	4.06	14.14	4.80	8.00	3.25	.62x.88	3/8	2	-32 - 2 1/2-12	31.75	6.38	8.43	1/2 (4)	3	4.88	5.88
1236	6.26	7.75	30.25	4.06	26.14	4.80	8.00	3.25	.62x.88	3/8	2	-32 - 2 1/2-12	43.75	6.38	8.43	1/2 (4)	3	4.88	5.88
1248	6.26	7.75	42.25	4.06	38.14	4.80	8.00	3.25	.62x.88	3/8	2	-32 - 2 1/2-12	55.75	6.38	8.43	1/2 (4)	3	4.88	5.88
1724	8.62	10.50	17.00	5.43	12.00	7.31	10.50	4.25	0.69	3/8	3	-32 - 2 1/2-12	34.10	8.16	10.66	1/2 (4)	4	6.82	7.25
1736	8.62	10.50	29.00	5.43	24.00	7.31	10.50	4.25	0.69	3/8	3	-32 - 2 1/2-12	46.10	8.16	10.66	1/2 (4)	4	6.82	7.25
1748	8.62	10.50	41.00	5.43	36.00	7.31	10.50	4.25	0.69	3/8	3	-32 - 2 1/2-12	58.10	8.16	10.66	1/2 (4)	4	6.82	7.25

HCRF Code 61 Flange

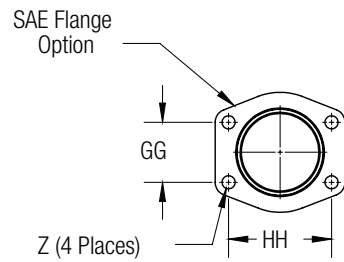

4 Bolt Flange

Series	Flange Size	GG	HH	Z
HCR-1200	2	1.69	3.06	1/2-13 UNC
HCR-1700	3	2.44	4.19	5/8-11 UNC

HCRA 150 # ASME Flange

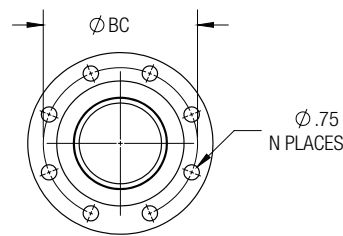

150# Flange

Series	Flange Size	BC	N
HCR-1200	2	4.75	4
HCR-1700	3	6	4

Dimensions

Two Pass

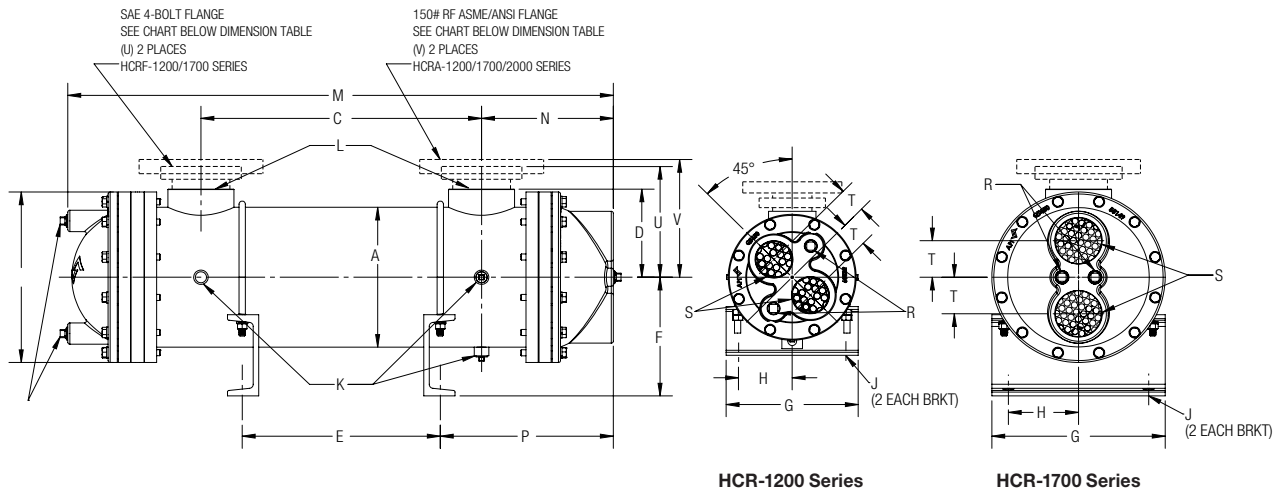

Model	A	B	C	D	E	F	G	H	J	K	L		M	N	P	R NPT	S NPT	T	U (HCRF)	V (HCRA)
											NPT/BSPP	SAE								
1224	6.26	7.75	18.25	4.06	14.14	4.80	8.00	3.25	.62x.88	3/8	2	-32 - 2 1/2-12	31.06	5.94	8.00	1/2 (4)	2	1.56	4.88	5.88
1236	6.26	7.75	30.25	4.06	26.14	4.80	8.00	3.25	.62x.88	3/8	2	-32 - 2 1/2-12	43.06	5.94	8.00	1/2 (4)	2	1.56	4.88	5.88
1248	6.26	7.75	42.25	4.06	38.14	4.80	8.00	3.25	.62x.88	3/8	2	-32 - 2 1/2-12	55.06	5.94	8.00	1/2 (4)	2	1.56	4.88	5.88
1724	8.62	10.50	17.00	5.43	12.00	7.31	10.50	4.25	0.69	3/8	3	-32 - 2 1/2-12	33.05	7.98	10.48	1/2 (4)	2 1/2	2.25	6.82	7.25
1736	8.62	10.50	29.00	5.43	24.00	7.31	10.50	4.25	0.69	3/8	3	-32 - 2 1/2-12	45.05	7.98	10.48	1/2 (4)	2 1/2	2.25	6.82	7.25
1748	8.62	10.50	41.00	5.43	36.00	7.31	10.50	4.25	0.69	3/8	3	-32 - 2 1/2-12	57.05	7.98	10.48	1/2 (4)	2 1/2	2.25	6.82	7.25

HCRF Code 61 Flange

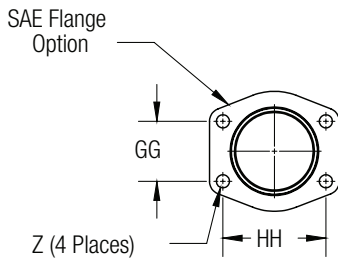

4 Bolt Flange

Series	Flange Size	GG	HH	Z
HCR-1200	2	1.69	3.06	1/2-13 UNC
HCR-1700	3	2.44	4.19	5/8-11 UNC

HCRA 150 # ASME Flange

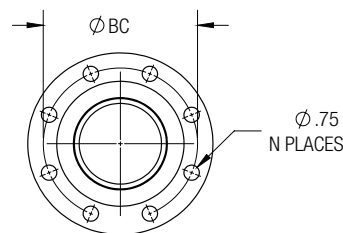

150# Flange

Series	Flange Size	BC	N
HCR-1200	2	4.75	4
HCR-1700	3	6	4