

FLUID COOLING | Mobile AOHM & AOVHM Series

Features

- AO/AOVH Series with Hydraulic Motor
- High Heat Removal
- Heavy Duty Construction
- Wide Flow Range
- Heat Removal up to 210,000 BTU/Hr.
- Long Life Hydraulic Motor
- NPT Connections



OPTIONS

- Built-in Relief Bypass Valve
- SAE or BSPP Connections
- Corrosion Resistant Coating

Ratings

- Operating Pressure** 300 psi
- Test Pressure** 300 psi
- Operating Temperature** 400° F

Materials

- Tubes** Copper
- Fins** Aluminum
- Turbulators** Steel
- Manifolds** Steel
- Connections** Steel
- Cabinet** Steel with Baked Enamel Finish
- Fan Blade** Aluminum with Steel Hub
- Fan Guard** Zinc Plated Steel
- Fan Adapter** Steel

How to Order

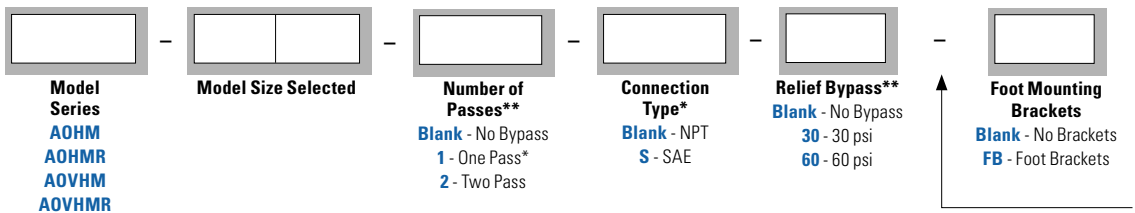

AOHMR - Relief Bypass Included
 AOVHMR - Relief Bypass Included (available in 2 pass only)

ADD FOR AOHM & AOVHMR MODELS ONLY

*Other connection types available. Please consult factory for assistance.

**ADD FOR AOHMR & AOVHMR MODELS ONLY

Dimensions

Fan Rotating Clockwise/Facing Motor Shaft

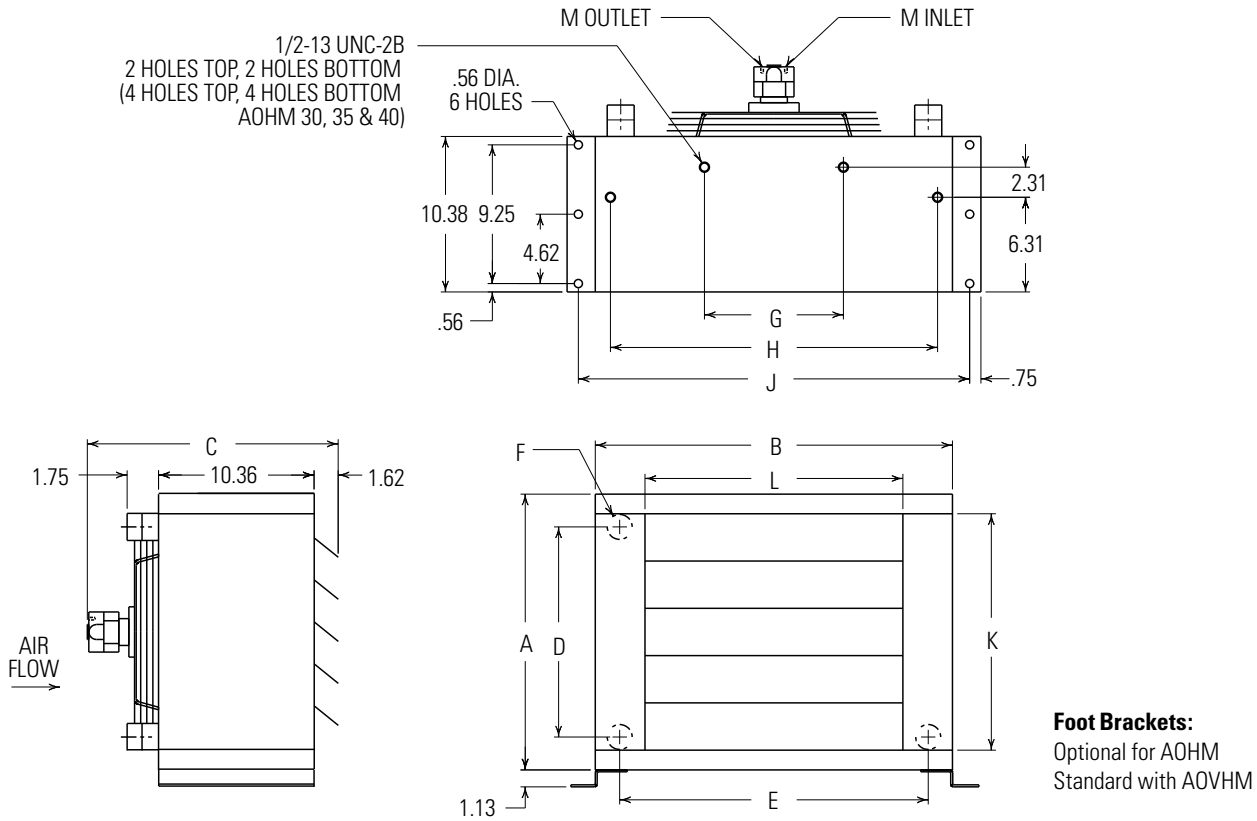

See dimensional chart for external NPT or optional internal SAE connection size.

MODEL	A	B	C	D	E	F		G	H	J	K	L	M (SAE)	NET WT (LBS)	
						NPT	SAE								
AOHM-5	11.81	14.81	16.70	7.69	11.69	1"	#16	-	12.94	16.81	9.19	8.31	#8	35	
AOVHM-5						1 1/2"	#24							59	
AOHM-10	13.12	19.00		8.88	15.88	1"	#16		17.12	21.00	10.50	12.50		50	
AOVHM-10						1 1/2"	#24							76	
AOHM-15	15.75	20.38	17.09	11.50	17.25	1"	#16		18.50	22.38	13.12	13.88		60	
AOVHM-15						1 1/2"	#24							89	
AOHM-20	18.38	23.81		14.00	20.56	1 1/4"	#20		21.81	25.81	15.75	17.19		75	
AOVHM-20						2"	#32							108	
AOHM-25	23.62	26.68	17.25	19.25	23.56	1 1/4"	#20		24.81	28.68	21.00	20.1 ⁹		110	
AOVHM-25						2"	#32							143	
AOHM-30	27.56	31.62	16.70	23.19	28.50	1 1/4"	#20		11.00	29.75	33.62	24.94		25.12	120
AOVHM-30			16.95			2"	#32								178
AOHM-35	30.19	33.81	16.70	25.81	30.69	1 1/4"	#20	11.00	31.94	35.81	27.56	27.31	#10	220	
AOVHM-35			17.22			2"	#32						#8	160	
AOHM-40	36.75	41.62	16.70	32.38	38.50	1 1/4"	#20	13.25	39.75	43.62	34.12	35.12	#8	160	
AOVHM-40			17.22			2"	#32						#10	286	

NOTE: We reserve the right to make reasonable design changes without notice. All dimensions are in inches.

Performance Curves

AOHM Series

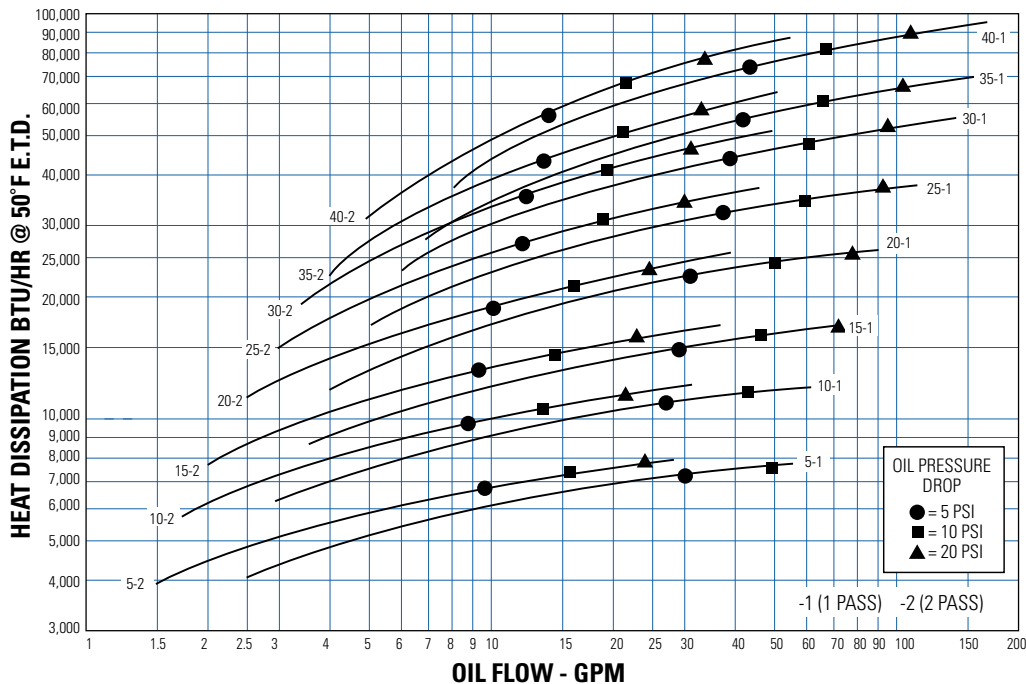

AOVHM Series

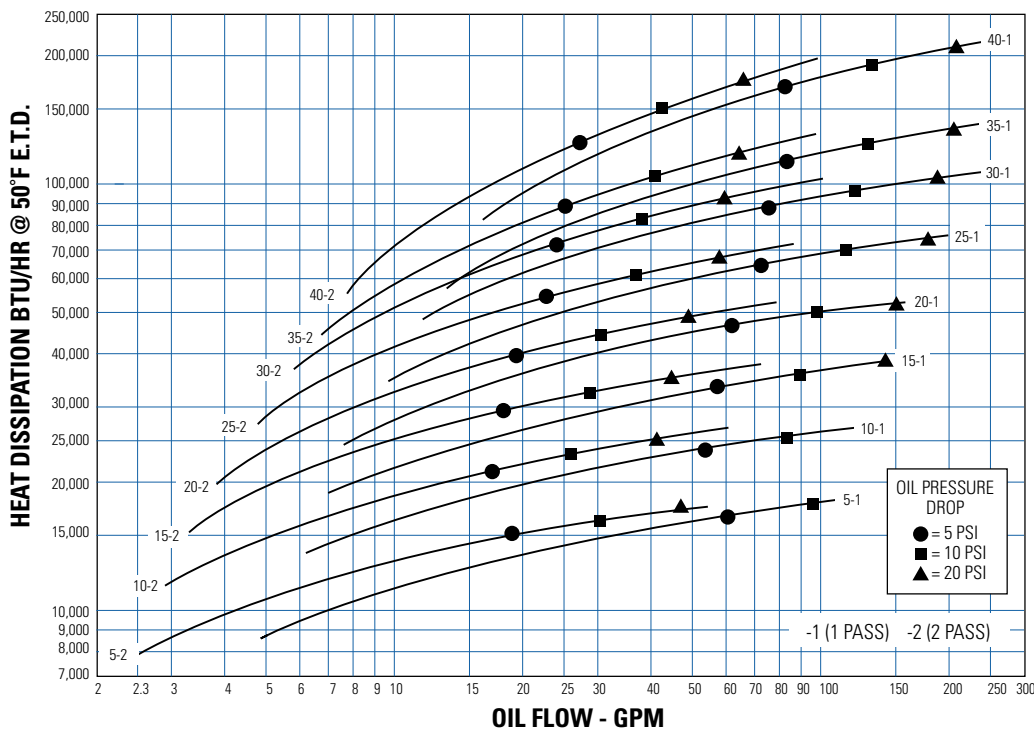

AIR COOLED
AOHM/AOVHM

Selection Procedure

Performance Curves are based on 50 SSU oil entering the cooler 50°F higher than the ambient air temperature used for cooling. This is referred to as a 50°F E.T.D.

Step 1 Determine the Heat Load. Heat load may be expressed as either horsepower or BTU/Hr. To convert horsepower to BTU/Hr.:
 $BTU/HR = \text{Horsepower} \times 2545$

Step 2 Determine Entering Temperature Difference. The entering oil temperature is generally the maximum desired oil temperature.
 Entering oil temperature – Ambient air temperature = E.T.D.

Step 3 Determine the Corrected Heat Dissipation to use the curves.
 Corrected Heat Dissipation =
 $BTU/HR \text{ heat load} \times \frac{50^\circ F}{E.T.D.} \times \text{viscosity correction A.}$

Step 4 Enter curves at oil flow through cooler and curve heat dissipation. Any curve above the intersecting point will work.

NOTE: Performance curves shown are for 1 and 2 pass configuration.

EXAMPLE: 35 - 2 is AOHM or AOVHM - 35

Step 5 Determine Oil Pressure Drop from Curves:
 ● = 5 PSI; ■ = 10 PSI; ▲ = 20 PSI. Multiply pressure drop from curve by correction factor B found in oil viscosity correction curve.

OIL VISCOSITY CORRECTION MULTIPLIERS

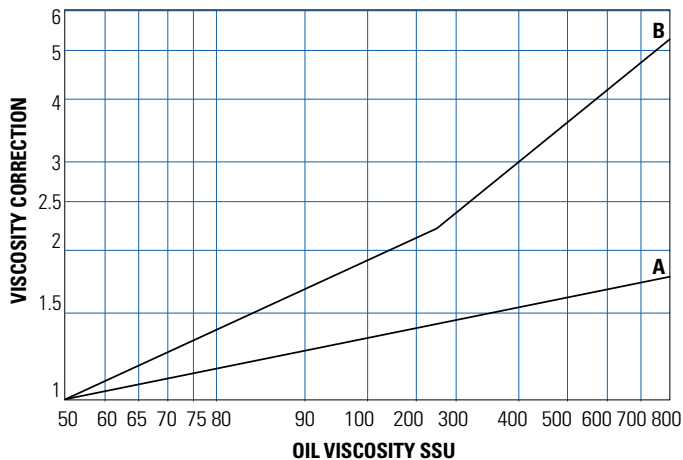

Desired Reservoir Temperature

Oil Temperature: Oil coolers can be selected using entering or leaving oil temperatures.

Off-Line Recirculation Cooling Loop: Desired reservoir temperature is the oil temperature entering the cooler.

Return Line Cooling: Desired reservoir temperature is the oil temperature leaving the cooler. In this case, the oil temperature change must be determined so that the actual oil entering temperature can be found. Calculate the oil temperature change (oil ΔT) with this formula:
 $\text{Oil } \Delta T = (BTU's/Hr.) / (GPM \text{ Oil Flow} \times 210).$

To calculate the oil entering temperature to the cooler, use this formula:
 $\text{Oil Entering Temp.} = \text{Oil Leaving Temp.} + \text{Oil } \Delta T.$

Oil Pressure Drop: Most systems can tolerate a pressure drop through the heat exchanger of 20 to 30 PSI. Excessive pressure drop should be avoided. Care should be taken to limit pressure drop to 5 PSI or less for case drain applications where high back pressure may damage the pump shaft seals.

Oil Temperature

Typical operating temperature ranges are:
 Hydraulic Motor Oil 120°F - 180°F
 Hydrostatic Drive Oil 160°F - 180°F
 Engine Lube Oil 180°F - 200°F
 Automatic Transmission Fluid 200°F - 300°F

Hydraulic Motor

MODEL SIZE	MAXIMUM FAN SPEED (RPM)		OIL FLOW REQUIRED (GPM)		MIN. OPERATING PRESSURE (PSI)		SOUND dB(A)*		MOTOR (in ³ /rev.) DISPLACEMENT		CFM		
	AOHM	AOVHM	AOHM	AOVHM	AOHM	AOVHM	AOHM	AOVHM	AOHM	AOVHM	AOHM	AOVHM	
5	1725	3450	1.6	3.3	300	300	68	85	.22	.22	465	780	
10							68	85			669	1110	
15							69	91			956	1590	
20							70	91			1460	2168	
25	1140	1725	1.1	3.4	400	500	72	81		.45	2160	3000	
30				75			84	2990			4095		
35				5.2	900	1000	76	89			.70	4370	5921
40							78	91				5450	9609

Notes: Maximum pressure is 2000 psi. Stated minimum operating pressure is at inlet port of motor. 1000 psi allowable back pressure.

*Catalog db(A) sound levels are at seven (7) feet. db(A) sound levels increase by six (6) dB(A) for halving this distance and decrease by (6) dB(A) for doubling this distance.

Built-In Relief Bypass

AOHMR Series

One Pass (Medium to High Oil Flows)

Model Number	Flow Range GPM (USA)
AOHMR - 5-1	2 - 80
AOHMR - 10-1	3 - 80
AOHMR - 15-1	4 - 80
AOHMR - 20-1	5 - 80
AOHMR - 25-1	6 - 100
AOHMR - 30-1	7 - 100
AOHMR - 35-1	8 - 112
AOHMR - 40-1	9 - 118

Two Pass (Low to Medium Oil Flows)

Model Number	Flow Range GPM (USA)
AOHMR - 5-2	2 - 25
AOHMR - 10-2	2 - 30
AOHMR - 15-2	2 - 40
AOHMR - 20-2	2 - 30
AOHMR - 25-2	2 - 40
AOHMR - 30-2	2 - 40
AOHMR - 35-2	3 - 40
AOHMR - 40-2	4 - 40

AOVHMR Series

Two Pass (Low to Medium Oil Flows)

Model Number	Flow Range GPM (USA)
AOVHMR - 5-2	4 - 50
AOVHMR - 10-2	4 - 60
AOVHMR - 15-2	4 - 60
AOVHMR - 20-2	4 - 80
AOVHMR - 25-2	4 - 80
AOVHMR - 30-2	4 - 80
AOVHMR - 35-2	6 - 80
AOVHMR - 40-2	8 - 80

Bypass valve is available for 2 pass AOVHMR models only.

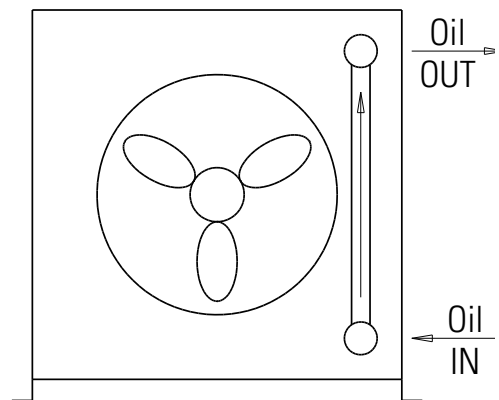
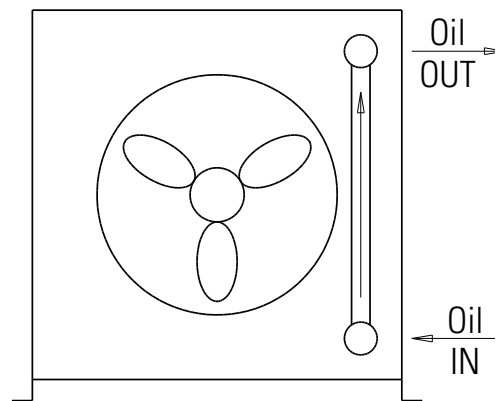
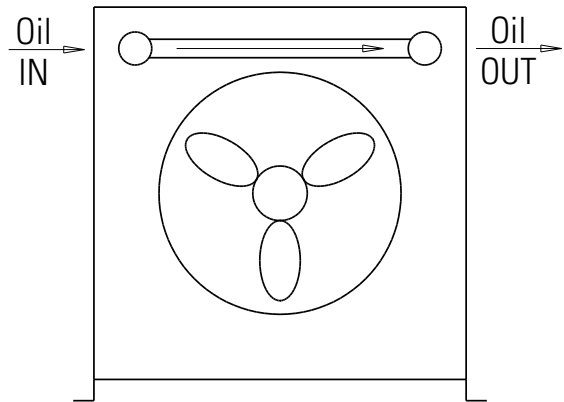

Installation Piping Diagrams

