

FLUID COOLING | Shell & Tube A Series

COPPER & STEEL CONSTRUCTION

Features

- ITT Interchange
- B or C Series is Recommended for New Applications
- Competitively Priced
- Optional Non-Ferrous Construction (Water-to-Water Service)
- Optional 90/10 Copper Nickel Cooling Tubes and Bronze End Bonnets for Sea Water Service
- NPT, SAE O-Ring, SAE Flange, or BSPP Shell Side Connections Available
- End Bonnets Removable for Servicing
- Mounting Feet Included (May be Rotated in 90° Increments)



WATER COOLED A

Ratings

- Maximum Shell Pressure** 300 psi
- Maximum Tube Side Pressure** 150 psi
- Maximum Temperature** 300° F

Materials

- Tubes** Copper
- Hubs & Tubesheets** Steel or Brass
- Shell** Steel or Brass
- Baffles** Brass
- End Bonnets** Cast Iron
- Mounting Brackets** Steel
- Gaskets** Nitrile Rubber/Cellulose Fiber
- Nameplate** Aluminum Foil

How to Order

<input type="text"/>	<input type="text"/>	<input type="text"/>	<input type="text"/>	<input type="text"/>	<input type="text"/>	<input type="text"/>	<input type="text"/>	<input type="text"/>
Model Series	Model Size Selected	Baffle Spacing	Tube Diameter Code	Tube Side Passes	Shell Material	Cooling Tube Material	End Bonnet Material	Zinc Anodes
SA SAF A AS AM AF AFM			4 - 1/4" 6 - 3/8"	0 - One Pass T - Two Pass F - Four Pass	Blank - Steel BR - Brass	Blank - Copper CN - CuNi	Blank - Cast Iron B - Bronze	Blank - None Z - Zinc

SA = NPT Shell side, NPT Tube. Available in 1200 & 1600 models only.
 SAF = SAE 4 Bolt Flange (with UNC threads) Shell side connections; NPT Tube side connections. Available in 1200 & 1600 models only.
 A = NPT Shell side connections; NPT Tube side connections
 AS = SAE O-Ring Shell side connections; NPT Tube side connections
 AM = BSPP Shell side connections; BSPP Tube side connections
 AF = SAE 4 Bolt Flange (with UNC threads) Shell side connections; NPT Tube side connections
 AFM = SAE 4 Bolt Flange (with Metric threads) Shell side connections; BSPP Tube side connections
SAE flanges available on some models. Consult factory for details.

Dimensions

One Pass

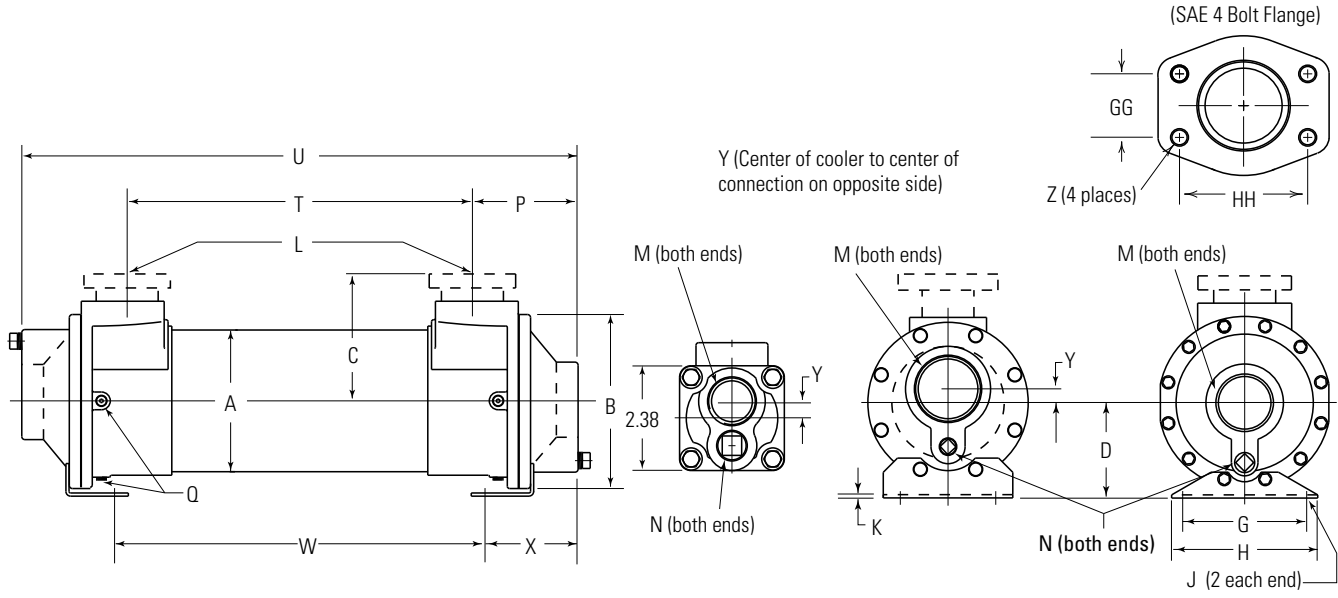

A-400 Series

A-600 & A-800 Series

A-1000, A-1200 & A-1600 Series

Flange Size	GG	HH	Z - CF	Z - CFM
1	1.03	2.06	3/8-16 UNC	M-10
1.50	1.41	2.75	1/2-13 UNC	M-12
2	1.69	3.06		
3	2.44	4.19	5/8-11 UNC	M-16

MODEL	A DIA.	B DIA.	C		D	G	H	J	K	L		M NPT	N NPT	P	Q NPT	T	U	W	X	Y
			NPT/BSPP SAE O-RING	SAE 4 BOLT FLANGE						NPT/BSPP FLANGE	SAE O-RING									
A-408	2.12	—	1.69	—	—	—	—	—	—	*1.00	N/A	.75	.38	2.38	—	6.25	11.00	—	—	.38
A-608	3.12	4.19	2.44	C/F	2.44	2.50	3.50	.38 x .88	.12	1.00	#16, 15/16-12 UNF-2B	1.50		2.56	(2) .25	12.12	17.25	11.47	3.06	
A-614													22.12			27.25	21.47			
A-624	4.12	5.88	3.12	C/F	3.50	3.50	4.75	.50 x 1.62	.12	1.50	#24, 17/8-12 UN-2B	2.00	3.44	(6) .38	11.12	18.00	12.88	2.56	.50	
A-814															21.12	28.00	22.88			
A-824	5.12	6.50	3.62	C/F	4.34	4.00	5.00	.50 x .88	.12	1.50	#24, 17/8-12 UN-2B	2.50	3.69	(6) .38	11.12	18.50	11.75	3.38	.50	
A-1014															21.12	28.50	21.75			
A-1024	6.12	7.50	4.25	C/F	4.84**	4.12	5.00	6.00	.12	2.00	#32, 21/2-12 UN-2B	3.00	4.25	(6) .25	33.12	40.50	33.75	3.75	.50	
A-1036															20.50	29.00	21.50			
A-1224	8.00	9.75	5.62	C/F	6.12***	5.38	7.00	8.25	.19	3.00	—	3.00	6.00	(6) .25	19.00	31.00	20.50	5.25	.50	
A-1236															31.00	43.00	32.50			
A-1248	8.00	9.75	5.62	C/F	6.12***	5.38	7.00	8.25	.19	3.00	—	3.00	6.00	(6) .25	43.00	55.00	44.50	5.25	.50	
A-1648															55.00	67.00	56.50			
A-1660	8.00	9.75	5.62	C/F	6.12***	5.38	7.00	8.25	.19	3.00	—	3.00	6.00	(6) .25	67.00	79.00	68.50	5.25	.50	
A-1672															67.00	79.00	68.50			

*A-408 SAE Flange not available. **SAF-1200 5.88. ***SAF-1600 7.38.

NOTE: We reserve the right to make reasonable design changes without notice. Consult factory. All dimensions are inches.

Dimensions

Two Pass

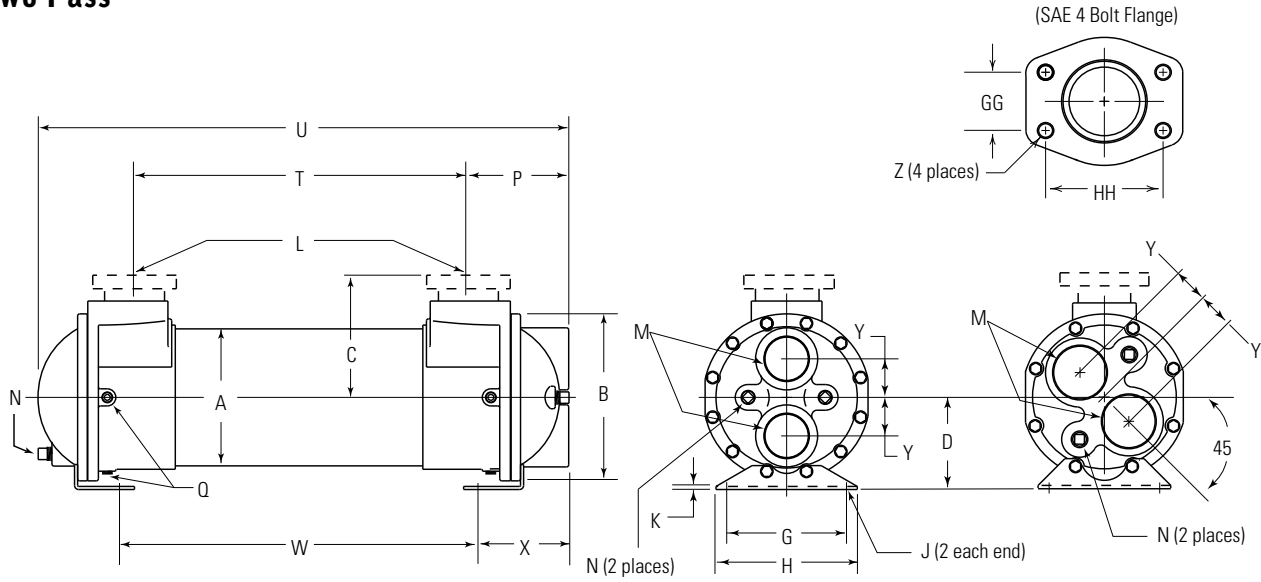

**A-600, A-800, A-1000
& A-1600 Series**

A-1200 Series

Flange Size	GG	HH	Z - CF	Z - CFM
1	1.03	2.06	3/8-16 UNC	M-10
1.50	1.41	2.75	1/2-13 UNC	M-12
2	1.69	3.06		
3	2.44	4.19	5/8-11 UNC	M-16

MODEL	A DIA.	B DIA.	C		D	G	H	J	K	L		M NPT	N NPT	P	Q NPT	T	U	W	X	Y
			NPT/BSPP SAE O-RING	SAE 4 BOLT FLANGE						NPT/BSPP FLANGE	SAE O-RING									
A-608	3.12	4.19	2.44	C/F	2.44	2.50	3.50	.38 x .88	.12	1.00	#16, 15/16-12 UNF-2B	1.00	.38	2.44	(2) .25	6.12	10.75	5.47	2.94	1.00
A-614																12.12	16.75	11.47		
A-624																22.12	26.75	21.47		
A-814	4.12	5.88	3.12	C/F	3.50	3.50	4.75	.50 x 1.62	.12	1.50	#24, 17/8-12 UN-2B	1.25	.38	3.44	(6) .38	11.12	17.62	12.88	2.56	1.19
A-824																21.12	27.62	22.88		
A-836																33.12	39.62	34.88		
A-1014	5.12	6.50	3.62	4.34	4.00	5.00	.50 x .88	.19	.12	1.50	#32, 2 1/2-12 UN-2B	1.50	.50	3.69	(6) .25	11.12	18.31	11.75	3.38	1.50
A-1024																21.12	28.31	21.75		
A-1036																33.12	40.31	33.75		
A-1224	6.12	7.50	4.25	4.84*	4.12	5.00	6.00	.50 x .88	.19	2.00	#32, 2 1/2-12 UN-2B	2.00	.50	4.25	(6) .25	20.50	28.75	21.50	3.75	1.56
A-1236																32.50	40.75	33.50		
A-1248																44.50	52.75	45.50		
A-1260	8.00	9.75	5.62	6.12**	5.38	7.00	8.25	.62 x 1.12	.19	3.00	—	2.50	.50	6.00	(6) .25	56.50	64.75	57.50	5.25	2.25
A-1624																19.00	30.50	20.50		
A-1636																31.00	42.50	32.50		
A-1648	8.00	9.75	5.62	6.12**	5.38	7.00	8.25	.62 x 1.12	.19	3.00	—	2.50	.50	6.00	(6) .25	43.00	54.50	44.50	5.25	2.25
A-1660																55.00	66.50	56.50		
A-1672																67.00	78.50	68.50		

*SAF-1200 5.88. **SAF-1600 7.38.

NOTE: We reserve the right to make reasonable design changes without notice. Consult factory. All dimensions are inches.

WATER COOLED A

Dimensions

Four Pass

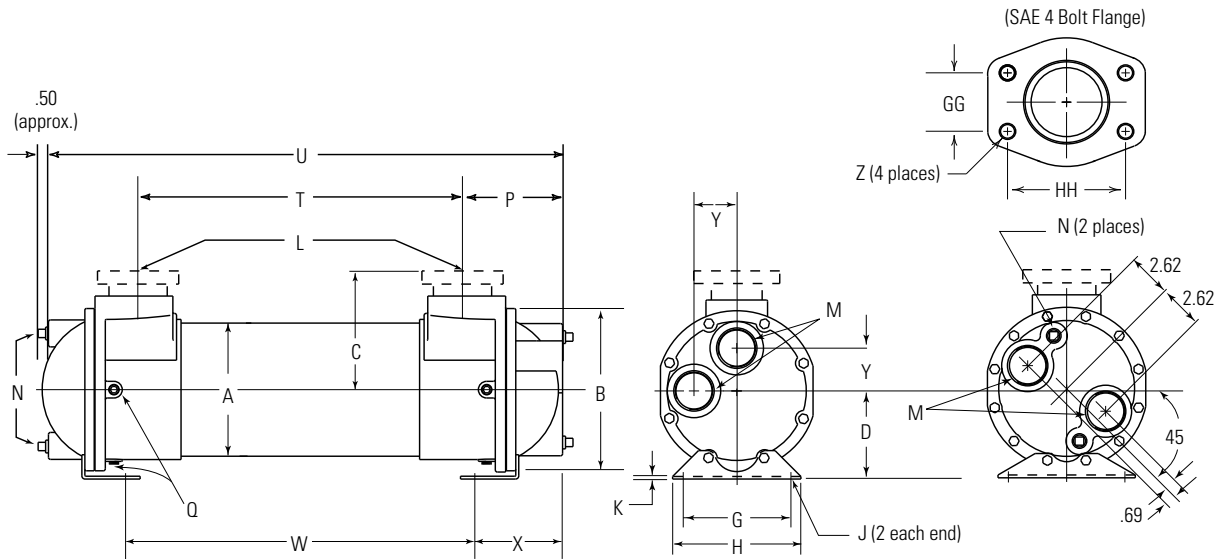

**A-600, A-800, A-1000
& A-1200 Series**

A-1600 Series

Flange Size	GG	HH	Z - CF	Z - CFM
1	1.03	2.06	3/8-16 UNC	M-10
1.50	1.41	2.75	1/2-13 UNC	M-12
2	1.69	3.06		
3	2.44	4.19	5/8-11 UNC	M-16

MODEL	A DIA.	B DIA.	C		D	G	H	J	K	L		M NPT	N NPT	P	Q NPT	T	U	W	X	Y
			NPT/BSPP SAE O-RING	SAE 4 BOLT FLANGE						NPT/BSPP FLANGE	SAE O-RING									
A-608	3.12	4.19	2.44	C/F	2.44	2.50	3.50	.38 x .88	.12	1.00	#16, 15/16-12 UNF-2B	.75		2.31	(2) .25	6.12	10.88	5.47	2.81	1.00
A-614																12.12	16.88	11.47		
A-624																22.12	26.88	21.47		
A-814	4.12	5.88	3.12	C/F	3.50	3.50	4.75	.50 x 1.62	.12	1.50	#24, 17/8-12 UN-2B	.38		3.44	(6) .38	11.12	17.62	12.88	2.56	1.06
A-824																21.12	27.62	22.88		
A-836																33.12	39.62	34.88		
A-1014	5.12	6.50	3.62	C/F	4.00	5.00	.50 x .88	.12	1.50	#24, 17/8-12 UN-2B	1.00		3.56			11.12	18.38	11.75	3.25	1.69
A-1024																21.12	28.38	21.75		
A-1036																33.12	40.38	33.75		
A-1224	6.12	7.50	4.25	C/F	4.12	5.00	6.00	.50 x .88	1.20	2.00	#32, 2 1/2-12 UN-2B	1.50		4.25	(6) .25	20.50	29.00	21.50	3.75	2.00
A-1236																32.50	41.00	33.50		
A-1248																44.50	53.00	45.50		
A-1260	8.00	9.75	5.62	C/F	5.38	7.00	8.25	.62 x 1.12	.19	3.00	—	2.00		6.00		56.50	65.00	57.50	5.25	—
A-1624																19.00	30.75	20.50		
A-1636																31.00	42.75	32.50		
A-1648	8.00	9.75	5.62	C/F	5.38	7.00	8.25	.62 x 1.12	.19	3.00	—	2.00		6.00		43.00	54.75	44.50	5.25	—
A-1660																55.00	66.75	56.50		
A-1672																67.00	78.75	68.50		

*SAF-1200 5.88. **SAF-1600 7.38.

NOTE: We reserve the right to make reasonable design changes without notice. Consult factory. All dimensions are inches.

Performance Curves

Model	Ship Wt. (lbs)
1. A-408-2-4-0	7
2. A-408-75-4-0	7
3. A-608-2-4-F	12
4. A-614-4-4-F	17
5. A-624-4-4-F	20
6. A-608-1-4-F	12
7. A-614-1.5-4-F	17
8. A-624-2-4-F	20
9. A-814-3-4-F	40
10. A-824-4-4-F	50
11. A-836-4-4-F	58
12. A-814-1.5-4-F	40
13. A-824-2-4-F	50
14. A-836-2-4-F	58
15. A-1014-3-6-F	49
16. A-1024-4-6-F	63
17. A-1036-4-6-F	72
18. A-1024-2-6-F	63
19. A-1036-2-6-F	72
20. A-1224-4-6-F	78
21. A-1236-6-6-F	118
22. A-1248-6-6-F	143
23. A-1260-6-6-F	165
24. A-1224-2-6-F	78
25. A-1236-3-6-F	118
26. A-1248-3-6-F	143
27. A-1260-4-6-F	165
28. A-1624-6-6-F	180
29. A-1636-6-6-F	210
30. A-1648-6-6-F	250
31. A-1660-6-6-F	286
32. A-1672-6-6-F	330
33. A-1624-2-6-F	180
34. A-1636-3-6-F	210
35. A-1648-3-6-F	250
36. A-1660-4-6-F	286
37. A-1672-4-6-F	330

Shipping weights are approximate

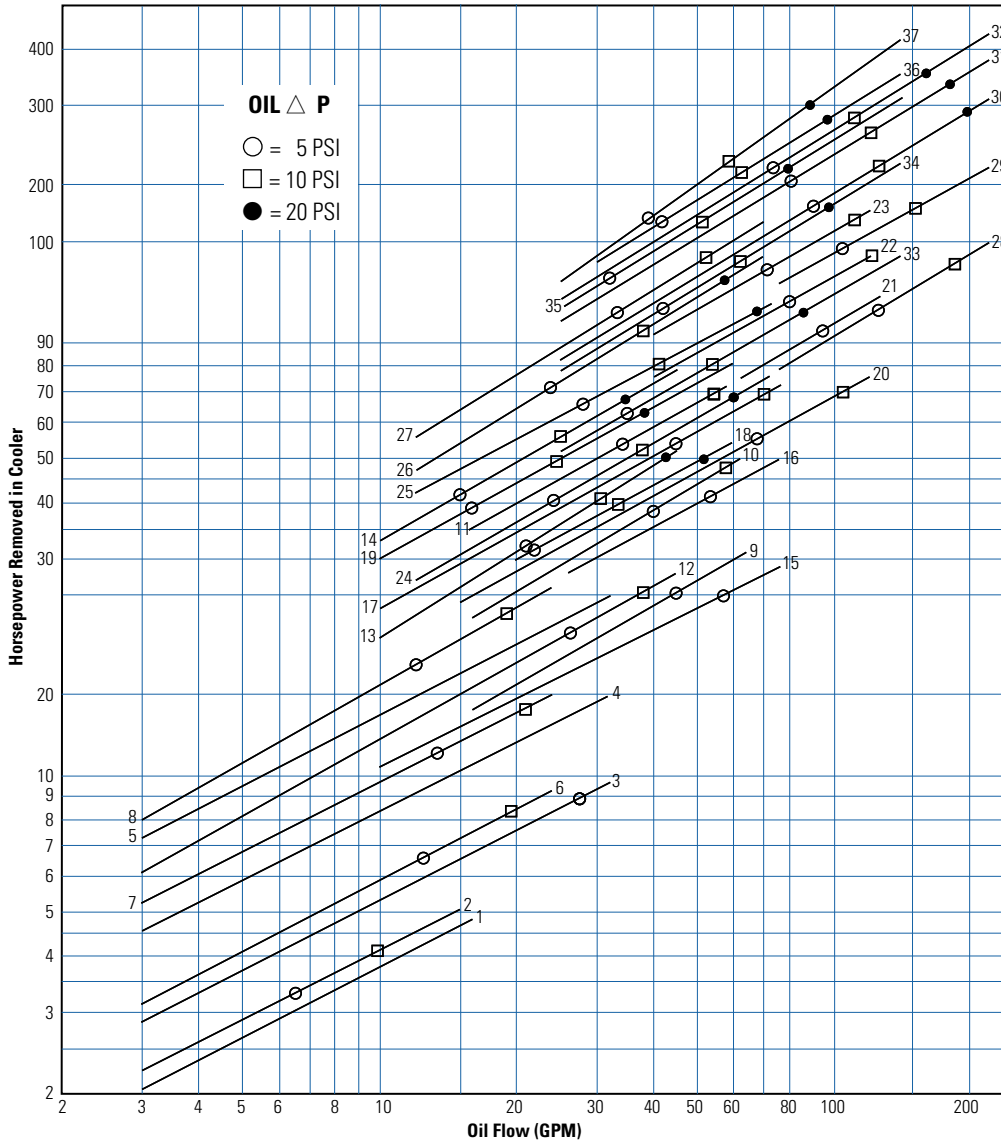

WATER COOLED A

Piping Hook-up

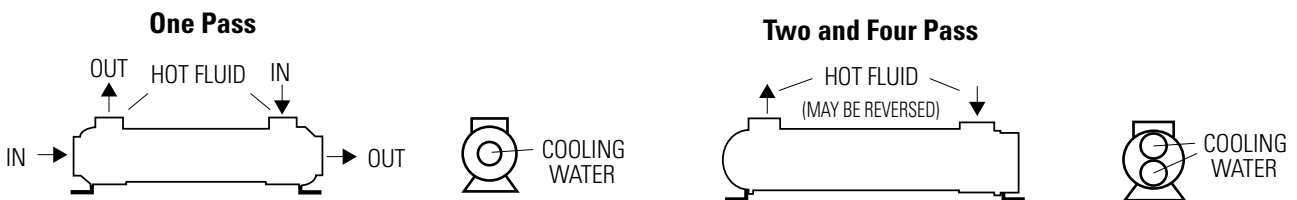

Specific applications may have different piping arrangements. Contact factory for assistance.

Selection Procedure

Performance Curves are based on 100SSU oil leaving the cooler 40°F higher than the water temperature used for cooling. This is also referred to as a 40°F approach temperature. Curves are based on a 2:1 oil to water flow ratio.

Step 1 Determine the Heat Load. This will vary with different systems, but typically coolers are sized to remove 25 to 50% of the input nameplate horsepower. (Example: 100 HP Power Unit x .33 = 33 HP Heat load.)
If BTU/Hr. is known: $HP = \frac{BTU/Hr}{2545}$

Step 2 Determine Approach Temperature. Desired oil leaving cooler °F – Water Inlet temp. °F = Actual Approach (Max. reservoir temp.)

Step 3 Determine Curve Horsepower Heat Load. Enter the information from above:
Horsepower heat load x $\frac{40}{\text{Actual Approach}}$ x Viscosity = Curve Horsepower
Correction A

Step 4 Enter curves at oil flow through cooler and curve horsepower. Any curve above the intersecting point will work.

Step 5 Determine Oil Pressure Drop from Curves:
○ = 5 PSI; □ = 10 PSI; ● = 20 PSI. Multiply pressure drop from curve by correction factor B found on oil viscosity correction curve.

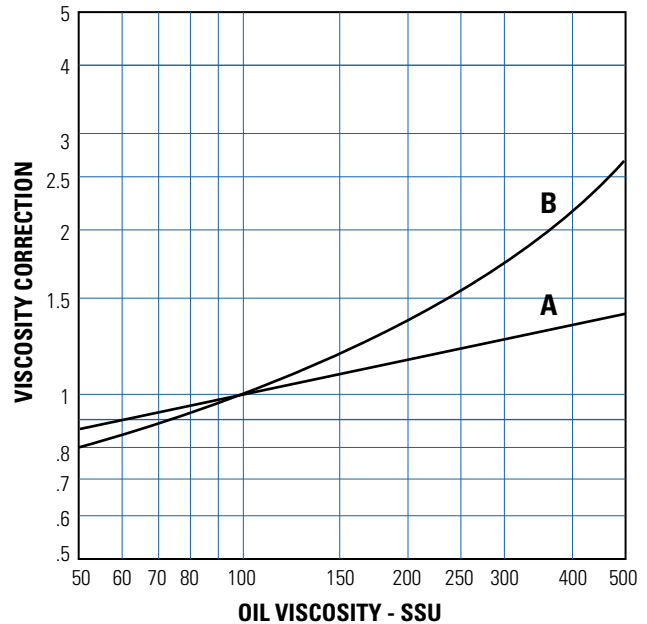

Oil Temperature

Oil coolers can be selected using entering or leaving oil temperatures.

Typical operating temperature ranges are:
Hydraulic Oil 110°F - 130°F
Hydrostatic Drive Oil 130°F - 180°F
Bearing Lube Oil 120°F - 160°F
Lube Oil Circuits 110°F - 130°F

Desired Reservoir Temperature

Return Line Cooling: Desired temperature is the oil temperature leaving the cooler. This will be the same temperature that will be found in the reservoir.

Off-Line Recirculation Cooling Loop: Desired temperature is the oil temperature entering the cooler. In this case, the oil temperature change must be determined so that the actual oil leaving temperature can be found. Calculate the oil temperature change (oil ΔT) with this formula:

$$\text{Oil } \Delta T = (BTU's/Hr.) / (GPM \text{ Oil Flow} \times 210).$$

To calculate the oil leaving temperature from the cooler, use this formula:

$$\text{Oil Leaving Temp.} = \text{Oil Entering Temp} - \text{Oil } \Delta T.$$

This formula may also be used in any application where the only temperature available is the entering oil temperature.

Oil Pressure Drop: Most systems can tolerate a pressure drop through the heat exchanger of 20 to 30 PSI. Excessive pressure drop should be avoided. Care should be taken to limit pressure drop to 5 PSI or less for case drain applications where high back pressure may damage the pump shaft seals.

Maximum Flow Rates

Example Model No.

A - 1024 - 2 - 6 - F

Unit Size	Baffle Spacing	Shell Side (GPM)	Tube Side (GPM)		
			O	T	F
400	.75, 2	7, 19	18	–	–
608	1, 2	14, 29	48	24	12
614	1.5, 4	21, 29	48	24	12
624	2, 4	29	48	24	12
814	1.5, 3	29, 57	87	44	22
824 & 836	2, 4	38, 69	87	44	22
1014	1.5, 3	32, 64	146	73	37
1024 & 1036	2, 4	42, 69	146	73	37
1224	2, 4	51, 103	224	112	56
1236 & 1248	3, 6	77, 115	224	112	56
1260	4, 6	103, 115	224	112	56
1624	2, 6	66, 200	280	140	70
1636 & 1648	3, 6	100, 200	280	140	70
1660 & 1672	4, 6	133, 200	280	140	70

Caution: Incorrect installation can cause this product to fail prematurely, causing the shell side and tube side fluids to intermix.