

ACOC Series – Brazed Aluminum Compressed Air Cooling

The ACOC Series offers the best of both worlds in one compact, side by side, combination package. The design features rugged brazed aluminum bar & plate construction with detachable legs for ease of mounting. In a single combined core, the high-performing unit cools rotary screw compressor oil and compressed air. The compact design makes this unit ideal for field conversions, stringent space requirements and remote location mounting. The series includes fifteen models with flow capacities from 175-1800 SCFM (4.96-50.97 SCMM) to be used on compressors from 15-360 HP (11.2-268.5 KW).

Consult catalog for additional sizes and technical information.



How to Order

Model Series

ACOC

ACOC

Model Size Selected

400
725
950
1200
1600
2000
2500
3000
3500

Specify Motor Required

0 - No Motor
(includes Fan Blade & Fan Guard)
2 - Single Phase
3 - Three Phase
6 - 575 Volt

Recommended Typical Installation

1. Support piping as needed. Flexible connectors must be properly installed to validate warranty.
2. Coolers should not operate in ambient temperatures below 35°F (1°C). Consult factory for recommendations.
3. The fan cannot be cycled.
4. AHP coolers operated outdoors must be protected from weather. Consult factory for recommendations.
5. If ductwork or additional static resistance is added to the cooler airstream, an auxiliary air mover may be required.

Features

- Combination welded cores – air & oil core
- Brazed aluminum core/bar and plate
- Excellent for field conversions
- Vertical air flow
- Compact design
- Lightweight
- Compact, high performance all aluminum core assembly
- Designed specifically for rotary screw compressors
- Ideal for converting water cooled units to air cooled
- Eliminates high water and sewer costs
- Eliminates corrosion problems associated with water cooled units
- Excellent for heat recovery
- State-of-the-art heat transfer technology
- Detachable legs on ACOC (shipped unattached)
- Fixed mounting feet on ACOCH
- CRN available

Ratings

- Maximum Operating Pressure 250 PSI
- Maximum Operating Temperature 350°F

Materials

- Legs Steel with baked enamel finish
- Shroud Steel
- Core Brazed aluminum bar and plate
- Fan Aluminum hub, plastic blades
- Motor TEFC

Dimensions

ACOC – Vertical Air Flow

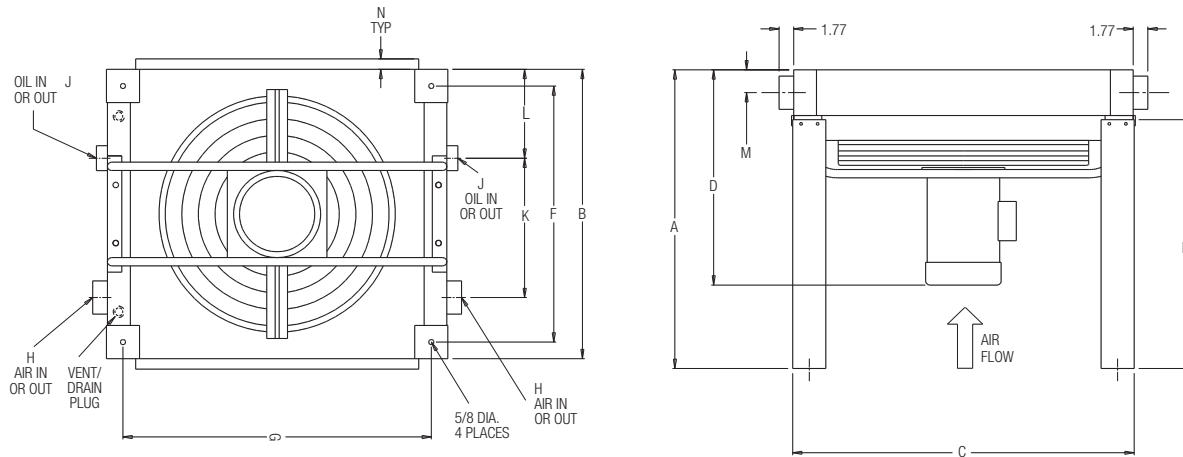

Model	A	B	C	D (Approximate)	E	F	G	H NPT	J NPT	K	L	M	N
ACOC-400	34.20	17.96	22.68	20.86	30.00	13.96	18.68	1.50	1.00	8.35	5.08	1.85	1.25
ACOC-725	34.20	22.37	30.56	20.86	30.00	18.37	26.56	1.50	1.00	10.55	6.34	1.85	1.25
ACOC-950	36.01	26.78	37.24	23.62	30.00	22.78	33.24	2.00	1.25	12.67	7.64	2.76	1.25
ACOC-1200	36.01	26.78	41.19	25.51	30.00	22.78	37.19	2.00	1.25	12.83	7.64	2.76	1.25
ACOC-1600	36.01	34.89	41.19	27.51	30.00	30.89	37.19	2.50	1.50	16.81	10.08	2.76	1.25
ACOC-2000	36.01	37.88	51.04	28.51	30.00	33.88	47.04	2.50	1.50	18.47	10.98	2.76	1.25
ACOC-2500	36.01	43.70	49.07	28.51	30.00	39.70	45.07	3.00	2.00	21.11	12.83	2.76	1.25
ACOC-3000	36.01	52.52	51.04	30.51	30.00	48.52	47.04	3.00	2.00	33.30	8.00	2.76	1.25
ACOC-3500	36.01	56.30	51.04	30.51	30.00	52.30	47.04	4.00	2.50	27.40	18.43	2.76	1.25

Note: We reserve the right to make reasonable design changes without notice. All Dimensions are in inches.

Selection Procedure

- STEP 1 Determine the Air Compressor's motor horsepower.**
- STEP 2 Enter the chart** at the motor horsepower to select the correct model.
- STEP 3 Check the aftercooler SCFM.** The SCFM of air discharged from the air compressor must be equal to or less than the value in the chart for the model selected. If it is not, choose a larger model. If the SCFM is unknown, multiply the air compressor's motor horsepower by 4.5 to determine the SCFM capacity required.

Model	Compressor HP	Aftercooler Maximum SCFM with 100 PSI air and a 15°F Approach Temperature
ACOC-400	15-35	175
ACOC-725	40-55	275
ACOC-950	60-85	425
ACOC-1200	90-120	600
ACOC-1600	125-155	775
ACOC-2000	160-225	1125
ACOC-2500	230-275	1375
ACOC-3000	280-325	1625
ACOC-3500	330-360	1800

Sizing

- Oil flow is .45 GPM/HP.
- Oil pressure drop - 15 PSI or less
- Oil heat transfer based on 100°F E.T.D.
(E.T.D. = Entering Temperature Difference)
(E.T.D. = Oil in Temperature - Ambient Air Temperature)
- Air aftercooler pressure drop - 3 PSI or less.
- E.T.D. Temperature Correction Factor:

$$HP_{chart} = HP_{compressor} \times \frac{100}{\text{Desired E.T.D.}}$$

Maintenance

Periodic cleaning of the fins with compressed air is needed to remove the accumulation of dirt and dust. Check the automatic drain on the separator (not included) periodically.

If the inside of the tubes need to be cleaned of oil and carbon, use a chlorinated solvent. Do not use strong solvents. Do not use acids or caustic cleaners.

Specifications

Electric Motor and Fan Data

Model	Fan CFM	Motor HP	Voltage	Phase	Full Load Amps 230V	HZ	RPM	Nema Frame	Thermal Overload	Net Weight (LBS)	Approximate Shipping Weight (LBS)
ACOC-400	2200	1.0	115/208-230	1	6.0	60 ¹	3450	56C	No	105	136
	1825/2200	1.0	208-230/460 ²	3	3.6/3.2	50/60	2850/3450	56C	No	105	136
ACOC-725	3600	1.5	115/208-230	1	8.5	60 ¹	3450	56C	No	149	155
	3025/2200	1.5	208-230/460 ³	3	4.8/4.2	50/60	2850/3450	56C	No	149	155
ACOC-950	4700	1.5	115/208-230	1	8.6	60 ¹	1740	145TC	No	223	280
	4700	1.5	208-230/460	3	4.6	60 ¹	1740	145TC	NO	223	280
ACOC-1200	7000	5.0	230	1	23.0	60 ¹	1740	184TC	No	297	410
	7000	3.0	208-230/460	3	8.8	60 ¹	1740	182TC	No	297	410
ACOC-1600	9700	5.0	208-230/460	3	13.4	60 ¹	1740	184TC	No	345	495
ACOC-2000	11000	7.5	230/460	3	19.6	60 ¹	1740	213TC	No	495	350
ACOC-2500	14000	7.5	230/460	3	19.6	60 ¹	1740	213TC	No	522	540
ACOC-3000	17500	10.0	230/460	3	24.8	60 ¹	1740	215TC	No	655	780
ACOC-3500	17500	10.0	230/460	3	24.8	60 ¹	1740	215TC	No	690	820

All motors shown are TEFC—Other motor options available upon request.

Published electrical ratings are approximate and may vary because of motor brand. Actual ratings are on motor nameplate.

⁽¹⁾ May also be operated at 50 Hz. Consult factory for details.

⁽²⁾ 50 Hz voltage: 190 - 200 - 208 - 220/380 - 400 - 415 - 440

⁽³⁾ 50 Hz voltage: 190 - 208/380 - 415

Bottom view of cooler to illustrate piping

