

# Thermostatic Temperature Controller (DC)

This controller was designed to mount on the cooler without requiring extensive wiring or plumbing. It provides accurate temperature control by cycling the cooling fan(s) to maintain desired oil temperature.

- 12 or 24 Volt operation
- Adjustable temperature settings range from 100°F thru 210°F
- For use with one or two fan models  
(Relay needed for 2 fan models – not offered by TTP)
- Temperature sensor provided
- Wiring provided for remote manual override
- Mounting hardware included



## Wiring Diagrams

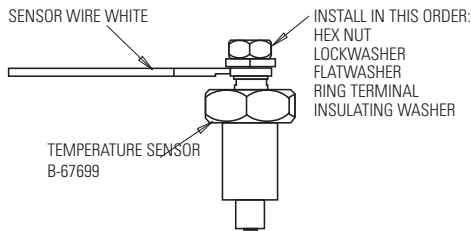
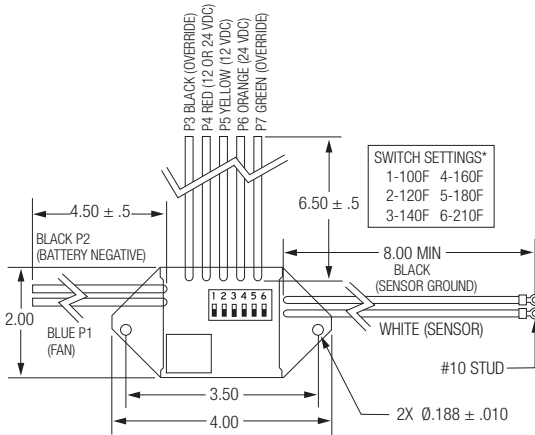

NOTE: This switch should be fused to prevent damage if ground is lost.  
 A 30 Amp Fuse is required in the power supply.  
 If manual override switch is not used, insulate P3 Black and P7 Green individually.

## Control Dimensions

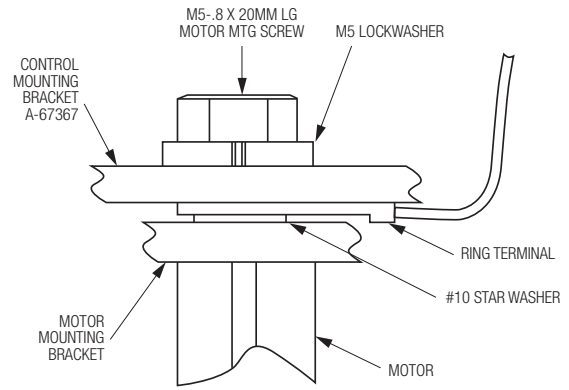

## Sensor Dimensions

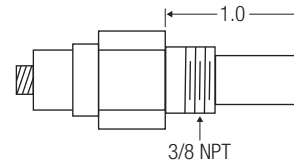

## Electrical Schematic

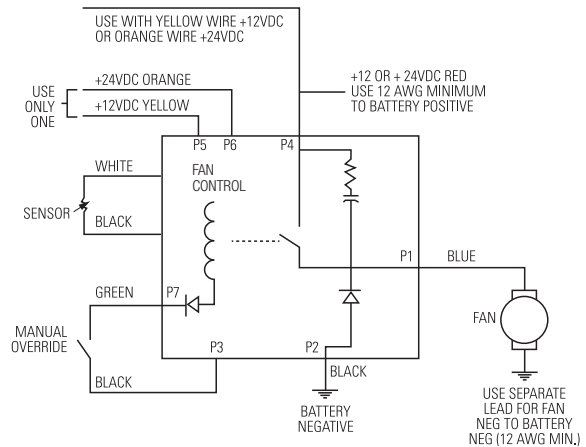

## Connection Assembly

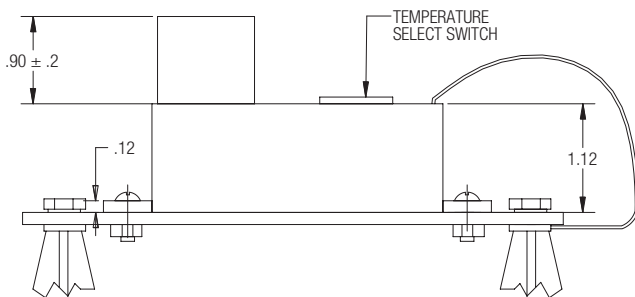

## How to Order

--	--	--	--	--

Part Number

- 96171** Electronic Fan Control Kit
- 68790** Replacement Control Only
- 67699** Replacement Sensor Only