

Compressed Air Separators



S-50 and S-100 Models

Two Models: One with a built-in automatic float style drain, the second with a 1/8" NPT connection with manual shut off valve. Rugged cast zinc housing. Equipped with quick disconnect bowls for easy service.



S-200 thru S-1700 Models

Four models to fit most applications. Unique high efficiency design provides wide SCFM capacity range without loss in performance. Sturdy, lightweight aluminum construction for long dependable service. NPT threaded drain connection for installation of an electronic, manual or automatic float style drain. Low differential pressure at maximum flow ratings. Externally and internally epoxy painted for maximum corrosion protection.



Model S-2600-M/S-2600-4F

1500 thru 3500 SCFM capacity. Consult factory for details on larger models thru 16,000 SCFM. (S-2600-4F shown above.)

Maintenance*

1. Depressurize unit before removing bowl.
2. A. If unit is equipped with a manual petcock, drain bowl at least once per workshift. More frequent draining may be required
B. If unit is equipped with an automatic float drain attached to the bowl, clean by turning bowl upside down, tapping on table top, and blow clean with airblow gun.
3. If bowl seal is cracked, damaged, or deteriorated, replace with approved seal.

*Service parts are not available.

Compressed Air Separators

Dimensions

Model Number	A	B	C	D	E (NPT)	F (NPT)	Weight LBS.
S-50 M	3.25	0.98	3.25	7.20	½"	⅛"	2.9
S-100 M	4.62	1.00	4.75	10.00	1"	⅛"	6.0
S-100 AD	4.62	1.00	4.75	10.00	1"	⅛"	6.0
S-200 M	5.10	1.60	4.38	10.80	1"	½"	4.8
S-300 M	6.70	2.00	4.38	17.00	1½"	½"	11.2
S-600 M	6.70	2.00	6.00	17.00	2"	½"	11.2
S-1700 M	8.10	2.40	7.75	19.90	3"	½"	22.0
S-2600 M	13.75	7.25	8.62	30.50	4"	¾"	85.0
S-2600 4F	16.75	7.25	8.62	30.50	4" Flg	¾"	100.0

*Supplied with manual shut off valve.

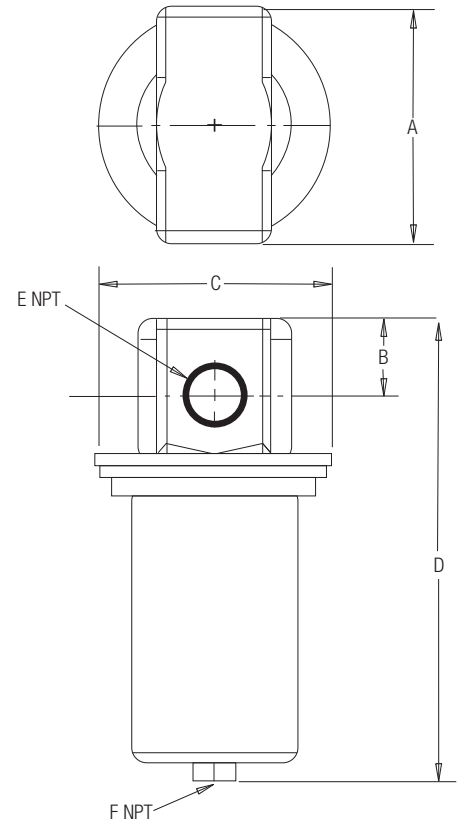

Specifications

Model Number	SCFM Range 100 PSIG		Δ P At Maximum SCFM	PSI Maximum	Temp °F Maximum	Bowl Maximum	Drain Type
	Minimum	Maximum					
S-50 M	5	50	0.5	200	175	Cast Zinc	Manual
S-50 AD	5	50	0.5	200	175	Cast Zinc	Automatic with Internal Float
S-100 M	11	120	0.5	200	175	Cast Zinc	Manual
S-100 AD	11	120	0.5	200	175	Cast Zinc	Automatic with Internal Float
S-200 M	11	233	0.7	232	176	Aluminum	Manual
S-300 M	60	472	1.0	232	176	Aluminum	Manual
S-600 M	100	742	1.3	232	176	Aluminum	Manual
S-1700 M	260	1700	1.0	232	176	Aluminum	Manual
S-2600 M	1500	3500	1.5	150	350	Carbon Steel	Manual
S-2600 4F	1500	3500	1.5	150	350	Carbon Steel	Manual

MINIMUM OPERATING TEMPERATURE - 35°F

Specifications and dimensions subject to change without notice.

Recommended Typical Installation

Air Cooled Equipment

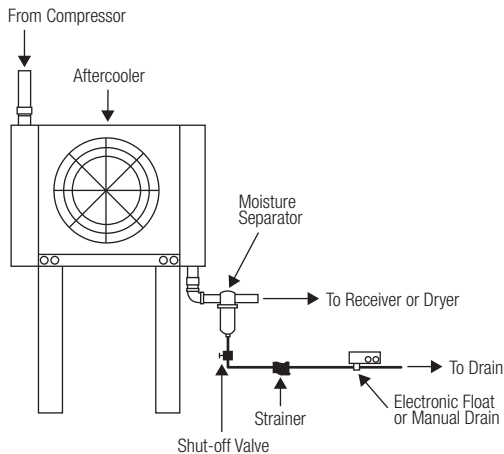

Water Cooled Equipment

